

WIRELESS MONITORING OF GAS SPRINGS IN THE TOOL **WIRELESS PRESSURE MONITORING 2.1**





WIRELESS PRESSURE MONITORING 2.1 (WPM) **WIRELESS MONITORING OF GAS SPRINGS VIA BLUETOOTH LE 4.0**

THE CORE REQUIREMENTS OF PRESS PLANTS ARE: AUTOMATION AND ZERO-ERROR MANUFACTURING. THE FIBRO WIRELESS PRESSURE MONITORING SYSTEM 2.1 (WPM), MONITORS GAS SPRINGS IN ALL AREAS, IN WHICH CABLE- OR HOSE CONNECTED SENSORS REACH THEIR TECHNICAL LIMITATIONS, OR ARE SIMPLY UNECONOMICAL.

The WPM system monitors the pressure and temperature in gas springs. It consists of a data part (optional) and sensors which transmit their data wirelessly to a WPM repeater integrated into the company network. Custom software analyses the data and initializes the necessary process control and preemptive maintenance steps accordingly. FIBRO, with the WPM system for the fourth industrial revolution,

provides a product and technology that supports concepts of intelligent processes and networked machines/tools.

ADVANTAGES

- Around-the-clock monitoring and documentation
- Early warning signalling prevents the production of unacceptable parts
- Preemptive wear detection and targeted troubleshooting
- Prevention of downtime and secondary failures
- Minimization of leakage points
- Streamlined construction and assembly
- Reduced maintenance and repair costs thanks to needs-optimised maintenance intervals

COMPONENTS OF THE WPM SYSTEM

- Sensors in the tool
- Data part (optional)
- WPM Repeater
- Fieldbus coupler (optional)
- WPM Cloud Software
- WPM app (optional)

WIRELESS PRESSURE MONITORING 2.1 (WPM) FOR INDUSTRY 4.0 (IOT) METHOD OF OPERATION



DETERMINE VALUES VIA BLUETOOTH

Sensors in the tool transmit the pressure and temperature values in the gas springs wirelessly.



MANAGE DATA

When using the WPM app, the data part manages the data of the tool sensors (optional).



COLLECT AND TRANSFER DATA

The FIBRO WPM repeater receives the data from the sensors and passes it on to the WPM cloud software. It establishes communication in all areas where you want to monitor your tools.

COMMUNICATION FOR CONTROL

The fieldbus coupler acts as an interface between the WPM cloud software and the system control of a power press or press line. It translates the MQTT protocol into an EtherCat or ProfiNet protocol and thus enables error-free communication within your systems.



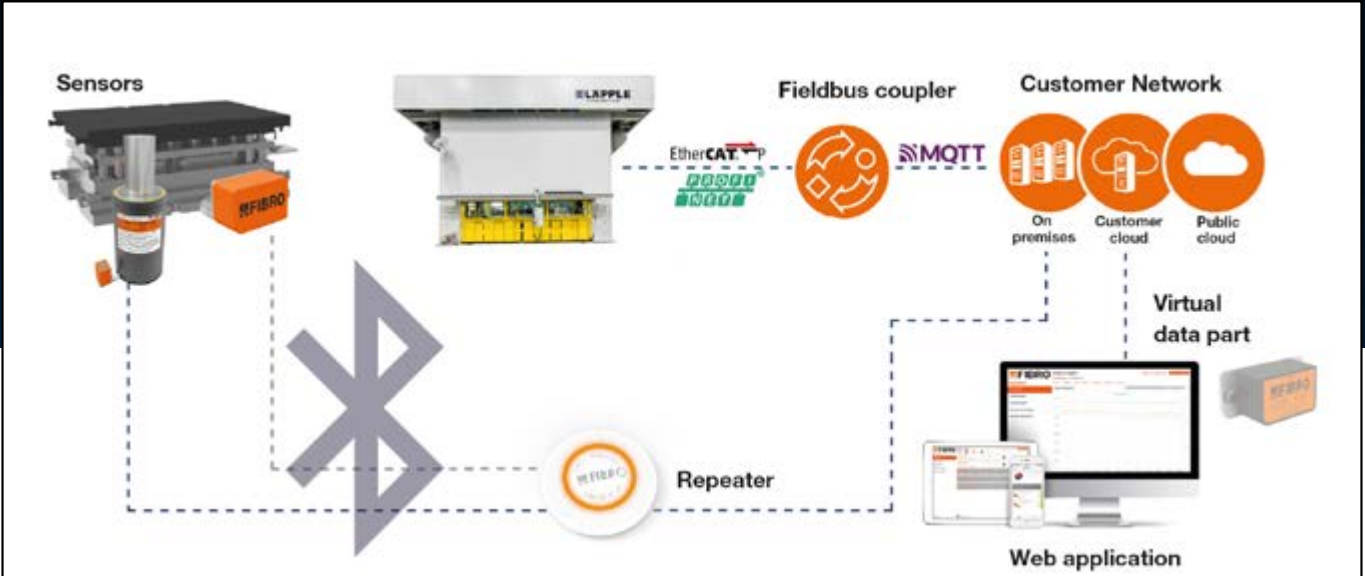

WEB-BASED SOFTWARE FOR SETTING UP AND EVALUATING THE SENSORS

The WPM system monitors the gas springs for error-free production before and during the use of the tool in the press.

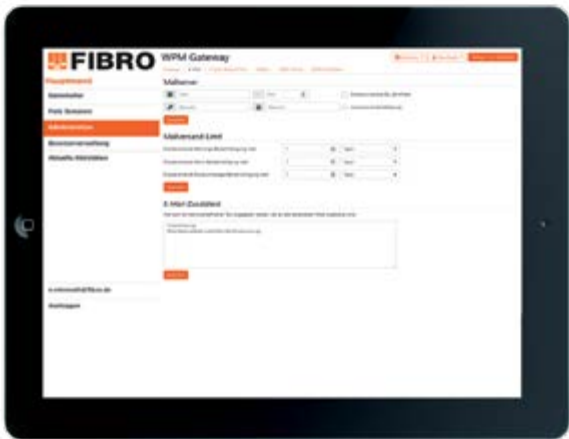

WPM CLOUD SOFTWARE

The WPM cloud software manages and controls your tools centrally and across locations. Installed on your server, you can create different plants or even different production areas such as press shop, maintenance workshop, warehouse or tool shop.

MOBILE APP

The WPM app is used to display the status conditions (pressure and temperature). It is available for download in the App Store, Google Play and on the FIBRO website.



WIRELESS PRESSURE MONITORING 2.1 (WPM) SENSOR, BATTERY

2480.00.91.10.01

Order number for sensor

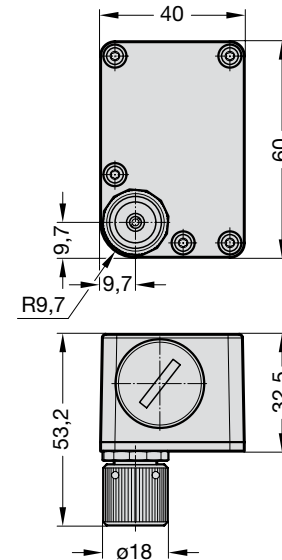
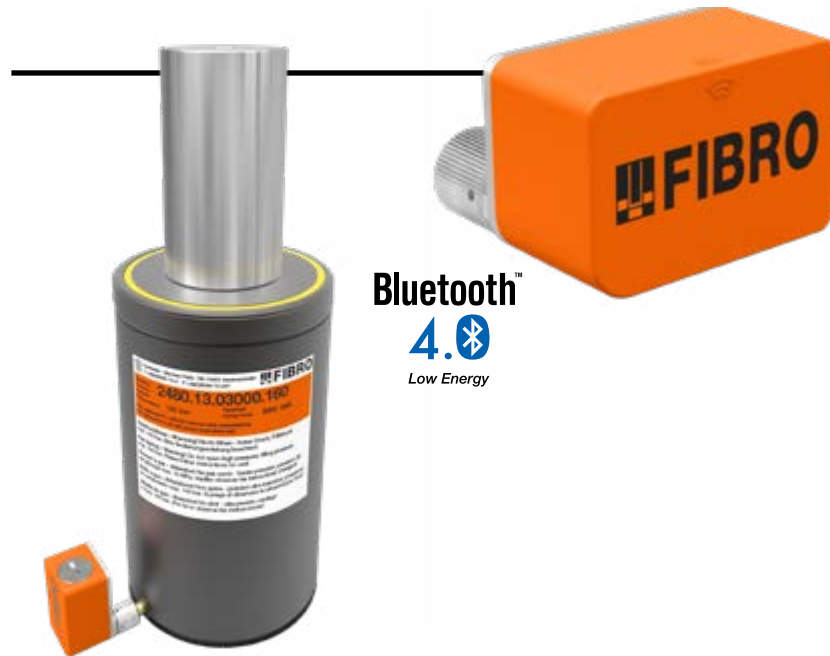

DESCRIPTION

The sensor is battery operated and thus wireless.

In operating mode, the sensor cyclically transmits data via Bluetooth LE 4.0 to the WPM repeater or the mobile WPM app.

The mechanical construction is designed according to the requirements of the press (shock- and vibration-resistant).

The data transmission during the programming of the sensor is encrypted.

The following data are queried:

- Limit values for pressure and temperature
- Part number (tool number)
- Part ID
- Sensor ID
- Position in the tool
- Various cycle times
- Battery status
- Transmission power

TECHNICAL SPECIFICATIONS

- Housing: plastic
- Base plate: Aluminium
- Minimes connection: Steel galvanised M12.65 x 1.5 FEM
- Pressure measuring range: 0 – 500 bar relative
- Precision: ± 2 bar
- Temperature measuring range: 0 °C to 85 °C
- Battery: Lithium Li-SoC12 2 / 3 A 3.6 V
- Signal transmission: Bluetooth LE 4.0
- Protection type: IP65 sealed with adhesive and screwed
- Operating temperature range: 0 °C to 80 °C

2480.00.91.10.00.1

Order number for battery reorder

(Battery is included with the sensor.)

Battery capacity 3 – 4 years for “normal” tool use

-

WIRELESS PRESSURE MONITORING 2.1 (WPM) **SENSOR, GAUGING COUPLING, FILLING ADAPTER**

MOUNTING EXAMPLE

Sensor connection to gas spring

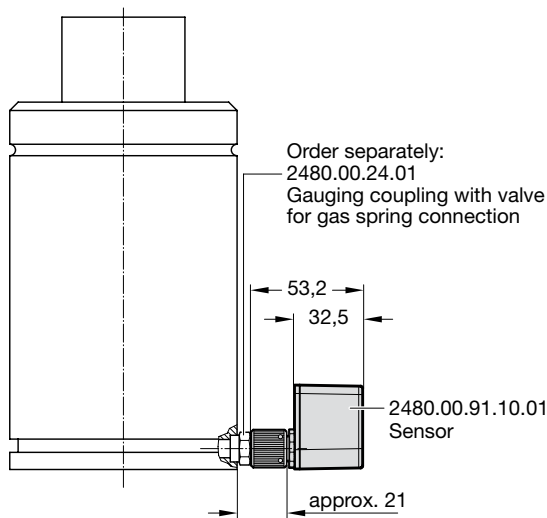

2480.00.24.01/02

- Measuring coupling 2480.00.24.01 with valve for connection to gas spring
- Measuring coupling 2480.00.24.02 with valve for connection to control fitting

2480.00.24.0x.

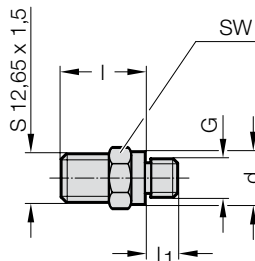

Order No.	G	d	SW	l	l ₁
2480.00.24.01	G 1/8	14	14	22	8
2480.00.24.02	G 1/4	19	19	21	10

SW = Width across flats

MOUNTING EXAMPLE

Sensor connection to control fitting

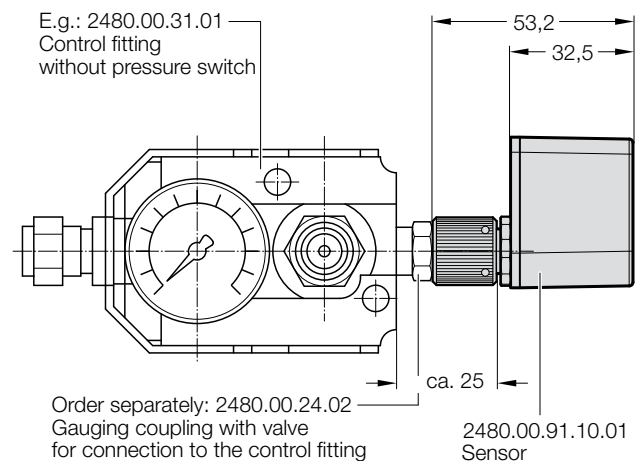

2480.00.90.00.10

Filling adapter for minimess connection

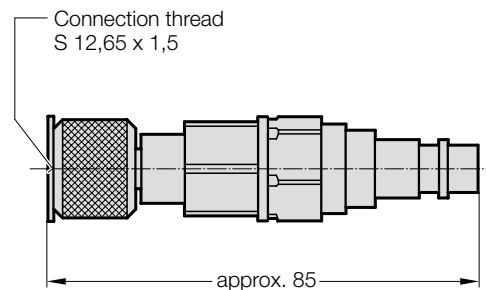

WIRELESS PRESSURE MONITORING 2.1 (WPM) DATA PART, BATTERY

2480.00.91.30



Bluetooth™
4.0
Low Energy

Order number for data part

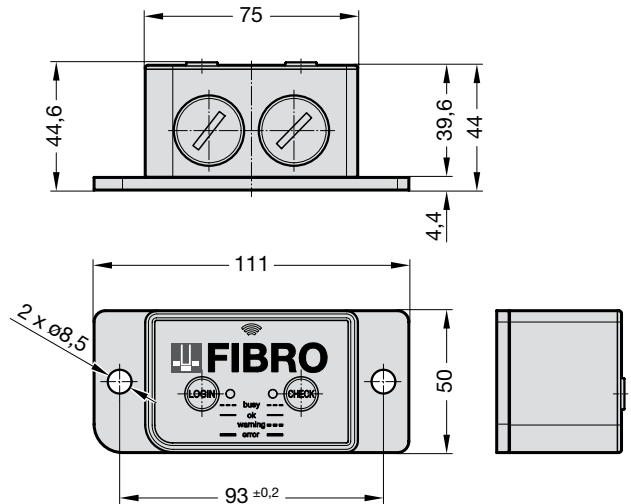

DESCRIPTION

A data part is installed in the tool when using the WPM app. It stores all the tool data, as well as a list of all sensors that are found on the tool.

Up to 128 sensors can theoretically be managed in one tool.

Via the CHECK button, the Data part can perform a quick tool scan (sensor condition such as pressure, battery and reception) with all the pressure sensors in the simplest manner.

The data part receives the connection with the Mobile WPM app and transmits its tool data.

NOTE

The tool data can be managed as a "virtual" data storage device in the cloud software. As a result, the data storage device 2480.00.91.30 is not mandatory for the cloud application.

2480.00.91.10.00.1

Order number for battery reorder

(2 batteries are included with the Data part.)

Battery capacity 3 – 4 years for "normal" tool use

—

TECHNICAL SPECIFICATIONS

- Housing: plastic
- Base plate: Aluminium
- Battery compartment cover: Aluminium
- Signal transmission: Bluetooth LE 4.0
- Protection type: IP65 sealed with adhesive and screwed
- Operating temperature: 0 °C to 60 °C

ADVANTAGES

- Wireless pressure monitoring
- Tool data are always available on the tool
- Data evaluation by gateway, PC (WPM software) or both possible in parallel
- Quick access to sensor data via short Bluetooth LE 4.0 cycle times
- Fast tool check by pressing a button on the data part with optical evaluation.

WIRELESS PRESSURE MONITORING 2.1 (WPM) REPEATER

2480.00.91.43



Order number for Repeater

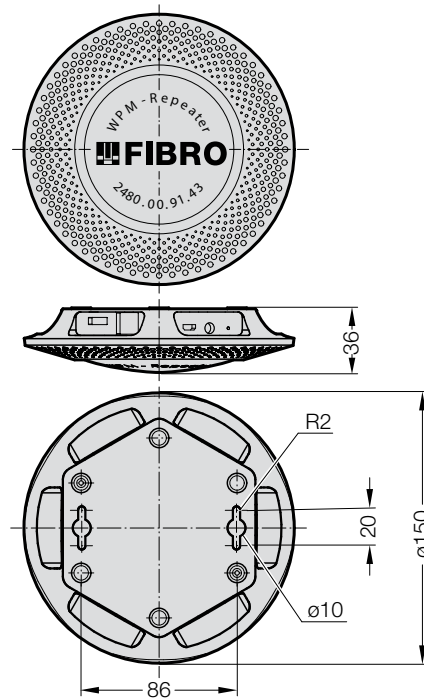

DESCRIPTION

The FIBRO WPM-Repeater 2480.00.91.43 establishes the communication with the sensors as well as the data storage device (optional) in which the tools are to be monitored.

The FIBRO WPM Repeater 2480.00.91.43 is a Bluetooth Low Energy (BLE) to WiFi connector. It collects the data from the WPM sensors and WPM storage devices and then sends it via MQTT protocol over WiFi or Ethernet to the WPM Cloud software 2480.00.91.53, which is installed on a local server or remote cloud server.

The FIBRO WPM Repeater is equipped on the top with a coloured light ring for status indications. It can be fastened by means of the screw mounts on the backside.

Mounting screws and a drill jig are included.

The mounting of the repeater should be vertically. Wall mounting is therefore preferable to ceiling mounting.

NOTE

The WPM Repeater 2480.00.91.43 can only be operated in conjunction with the WPM Cloud Software 2480.00.91.53!

TECHNICAL SPECIFICATIONS

- Housing: Plastic, white
- Dimension: $\varnothing 150$ mm x 36 mm
- Weight: 180 g
- Operating temperature range: -25°C up to 65°C
- Air humidity: max. 95% non-condensing
- Power supply: DC 5V
- with Micro USB: 330 mA
- Frequency band: 2,4 GHz
- Range: 25 - 50 m (Free field)

SUPPLIED COMPONENTS

WPM Repeater, 1x Micro-USB cable, power supply, mounting screws with jig

WIRELESS PRESSURE MONITORING 2.1 (WPM) **FIELDBUS COUPLER ETHERCAT**



2480.00.91.44.1

Order number for EtherCAT fieldbus coupler

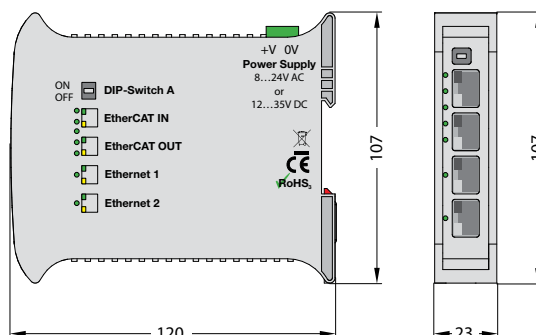

DESCRIPTION

By integrating the fieldbus coupler, EtherCAT 2480.00.91.44.1, the WPM Cloud application 2480.00.91.53. can be connected to the power press control (EtherCAT). The EtherCAT fieldbus coupler 2480.00.91.44.1 enables EtherCAT communication with the WPM system, connecting an EtherCAT master (e.g. a Beckhoff PLC, OMRON PLC, etc.) to the WPM cloud application 2480.00.91.53. The communication from network coupler to WPM-Cloud (MQTT) can be encrypted with TLS/SSL, which ensures a SECURE communication.

SYSTEM REQUIREMENTS

One fieldbus coupler is required for each power press control. The fieldbus coupler is connected to the WPM Cloud application via Ethernet (port 1883). Additional ports are required for configuration (80/443).

TECHNICAL SPECIFICATIONS

Housing: plastic PVC
 Connections: 4xEtherNET
 EtherNET protocol: MQTT
 EtherCAT protocol: EtherCAT Slave
 Data rate MQTT: 10/100 Base-T Autosensing
 Data rate EtherCAT: 10/100 Base-T Autosensing
 MQTT Connector: RJ45
 EtherCAT Connector: RJ45
 Power connection: 2way 5mm terminal block
 Power supply: 8..24V AC; 12..35V DC
 Operating temperature range: -40°C/+85°C
 Dimensions (LxWxH): 120x23x107
 Weight: approx. 200g
 Fastening: DIN rail

WIRELESS PRESSURE MONITORING 2.1 (WPM) **FIELDBUS COUPLER PROFINET**

2480.00.91.44.2

Order number for PROFINET fieldbus coupler

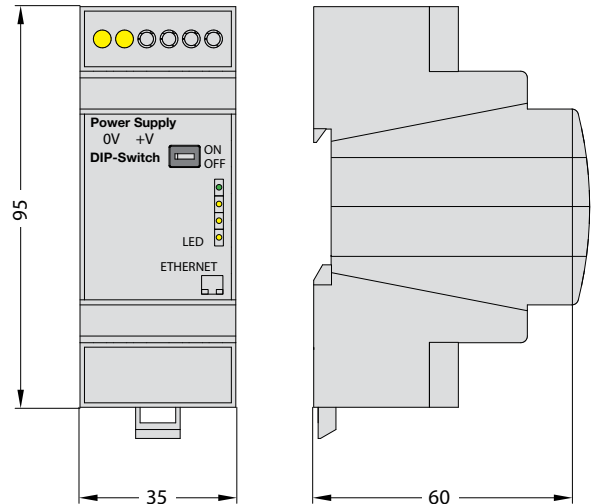

DESCRIPTION

By integrating the fieldbus coupler, PROFINET 2480.00.91.44.2, the WPM Cloud application 2480.00.91.53, can be connected to the power press control (PROFINET). The PROFINET 2480.00.91.44.2 fieldbus coupler enables PROFINET communication with the WPM system, connecting a PROFINET master (e.g. SIEMENS PLC, Supervisory PLC, etc.) with the WPM cloud application 2480.00.91.53. The communication from network coupler to WPM-Cloud (MQTT) can be encrypted with TLS/SSL, which ensures a SECURE communication.

SYSTEM REQUIREMENTS

One fieldbus coupler is required for each power press control. The fieldbus coupler is connected to the WPM Cloud application via EtherNet (port 1883). Additional ports are required for configuration (80/443).

TECHNICAL SPECIFICATIONS

Housing: plastic PVC
 Connections: 1xEtherNET
 EtherNET protocol: MQTT
 PROFINET protocol: PROFINET Slave
 Data rate MQTT: 10/100 Base-T Autosensing
 Data rate EtherCAT: 10/100 Base-T Autosensing
 MQTT Connector: RJ45
 PROFINET Connector: RJ45
 Power connection: 2way 5mm terminal block
 Power supply: 8..24V AC; 12..35V DC
 Operating temperature range: -40°C/+85°C
 Dimensions (LxWxH): 36x60x95
 Weight: approx. 200g
 Fastening: DIN rail

WIRELESS PRESSURE MONITORING 2.1 (WPM) WPM CLOUD SOFTWARE

THE WPM 2.1, LIKE ITS PREDECESSOR, WIRELESSLY MONITORS THE PRESSURE AND TEMPERATURE OF YOUR FIBRO GAS SPRINGS IN THEIR INSTALLED STATE. SENSORS WITHIN THE TOOL SEND DATA VIA BLUETOOTH TO THE REPEATER. THE REPEATER THEN TRANSMITS THIS DATA WIRELESSLY OR VIA LAN TO THE CLOUD-BASED SOFTWARE INSTALLED ON THE COMPANY SERVER. THE SPECIALLY DEVELOPED SOFTWARE ANALYZES THIS DATA AND TRIGGERS APPROPRIATE ACTIONS.

DESCRIPTION

The enhanced version 2.1 offers additional features that bring your production a big step closer to Industry 4.0:

The cloud-based solution makes it possible to monitor multiple tools at the same time – even across locations and sites. The Bluetooth range is therefore no longer a limiting factor.

Installing the Cloud on your internal company server reliably implements the absolute security of your sensible data.

Most accurate analyses of collected data allow an even more precise process control and an optimized preventive maintenance.

The future performance of the system can be enhanced by the option to add modular extensions with additional sensors.

An easy and intuitively user interface simplifies the operation, configuration and maintenance of the system and thereby helps prevent errors.

Additional functions such as the assignment of specific gas springs for simplified display of obtained values make the system even more user-friendly. The ordering of spare parts is thereby also possible automatically via our online store.

2480.00.91.53.

Order number for the WPM Cloud software



SYSTEM REQUIREMENTS

The software requires a Linux base system with Docker installed.

A WPM server must meet the following requirements:

- Working memory: at least 4GB, recommended 8GB
- Hard disk space: at least 64GB
- Processor: No special requirements
- Operating system: Ubuntu 20.04 (other distributions are possible, but without support)
- Docker version 20.10.8 or higher
- Internet access via port 443 must be provided at least for the installation
- A network connection between the server, the WPM gateways (network couplers) and WPM Repeaters must be possible via port 8883

THE WPM CLOUD SOFTWARE IS OFFERED ON A LICENSE MODEL:

2480.00.91.53.005 - 5 licenses

2480.00.91.53.010 - 10 licenses

2480.00.91.53.025 - 25 licenses

2480.00.91.53.100 - Unlimited licenses

One license is required per WPM Repeater or network coupler. This allows for optimal tailoring to your monitoring requirements.

WIRELESS PRESSURE MONITORING 2.1 (WPM) YOUR ADDED VALUES



ADVANTAGES:

- Setup and configuration of the tool sensors and the data part
- Trend detection and data analysis of the pressure and temperature gradients
- Proactive mailing functions to the user
- Option for integration into the press control system (as well as Beckhoff PLC and the Siemens PLC)
- Platform-independent web interface
- On Premise Integration into the company network locally at the customer's site
- Customer Cloud Integration
- Interface to the system network/company network via: EtherCat, Profinet, OPC-UA, Ethernet/WLAN/LAN, MQTT

PROACTIVE MAILING FUNCTIONS

STORAGE FOR SENSOR DATA

CLOUD INTEGRATION
OPTION

CROSS-PLATFORM

CROSS-MANUFACTURER
SYSTEM INTEGRATION

STANDALONE
COMMUNICATION

TREND DETECTION /
DATA ANALYSIS

REMOTE ACCESS

WIRELESS PRESSURE MONITORING 2.1 (WPM) CLOUD USER INTERFACE, IOT

SIMPLE CONFIGURATION OF THE SYSTEM

Setting and display of actual and setpoint values for pressure and temperature of the sensors in the tool via web-based user interface.

PRODUCE ERROR-FREE

Before and during the use of tools in the press, the WPM monitors the level of pressure of all gas springs. The system reports issues before the production of unacceptable parts can occur. Adjustable warning and alarm value limits. Via trend detection and data analysis, the user is informed by email when the set limit values are not reached.

POSITION AND STATUS CONTROL OF THE GAS SPRING SENSORS IN THE TOOL

System locates defective spring in case of malfunction.



TARGETED MAINTENANCE

Temperature monitoring can detect wear and tear even before a pressure drop in the spring. This significantly reduces the effort required for upkeep and maintenance compared to rigid intervals.



STREAMLINED CONSTRUCTION AND ASSEMBLY

Tool manufacturers only need to consider the position of sensors and springs. No need to install tube lines during assembly which means leakages are a thing of the past.



DOCUMENTATION OF THE PROCESS CONTROL (PRESSURE / TIME DIAGRAM)

Pressure and temperature data are acquired and recorded throughout the entire production process, but also, for example, in the warehouse or during maintenance.



WIRELESS PRESSURE MONITORING 2.1 (WPM) EXAMPLE APPLICATION AND INSTALLATION

INSTALLATION OF SENSORS

The sensors should ideally be connected directly to the gas pressure spring by means of the G1/8 Minimes coupling. Alternatively, they can be attached to a control panel (hose or manifold system). When attaching to a control panel, temperature monitoring of individual gas springs is not possible.



Connection of sensors directly to gas pressure springs

Attachment of sensor to control fitting for monitoring the composite system

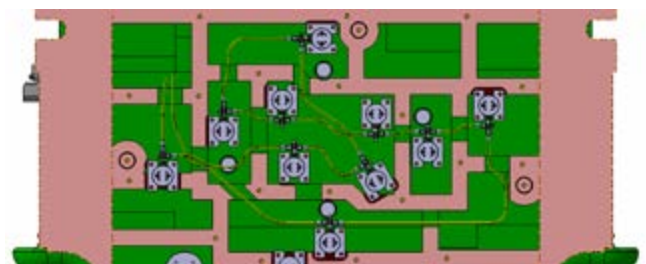
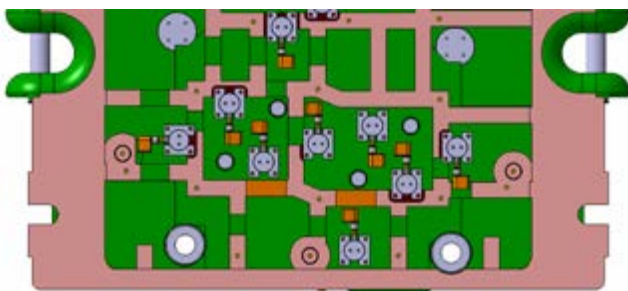

Caution: To avoid impairment of the radio transmission, there must be sufficient openings in the tool near sensors. Slotted openings with a minimum length of 50 mm are recommended. The width is freely selectable (> 0.2mm).

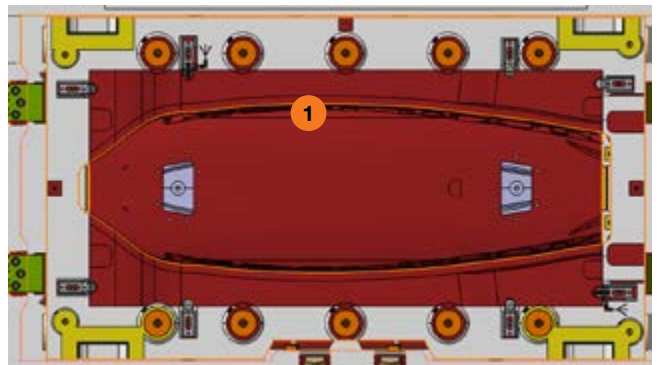
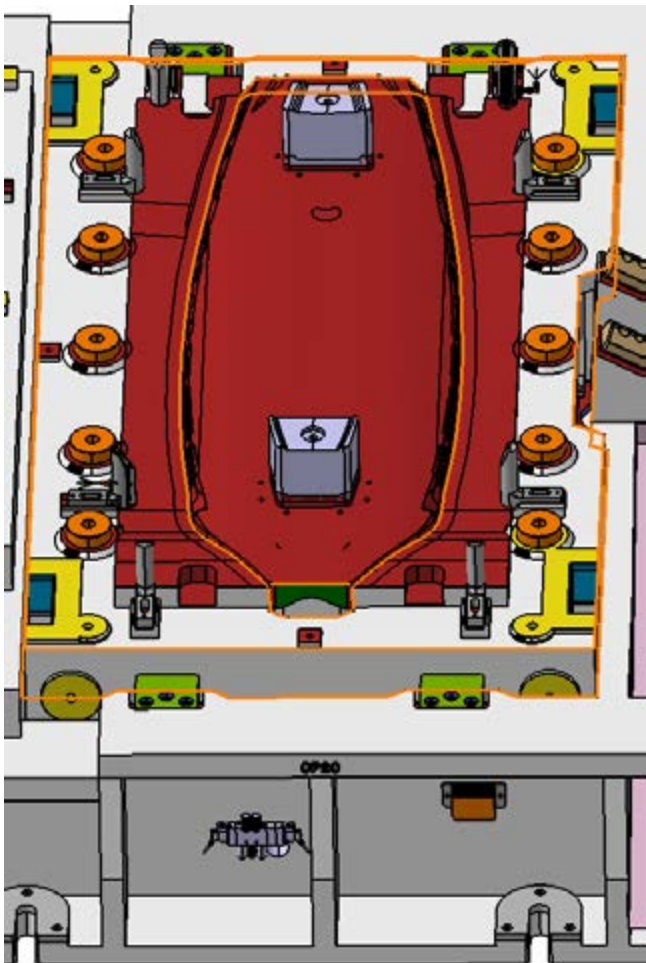
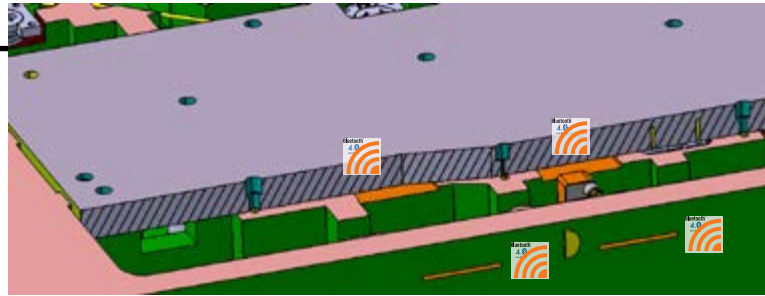

1) Slotted openings for radio transmission

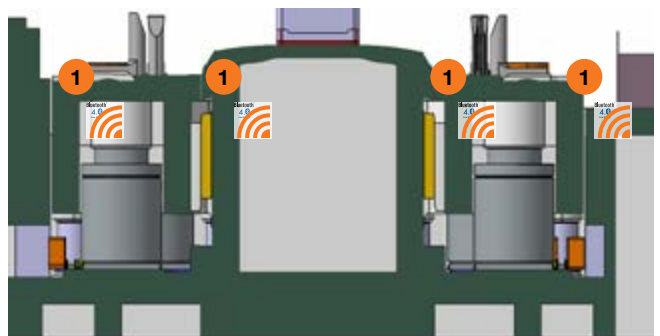

WIRELESS PRESSURE MONITORING 2.1 (WPM) **EXAMPLE APPLICATION AND INSTALLATION**

INSTALLATION OF DATA PART (OPTIONAL)

A data part can be installed on any tool (e.g. for using the mobile WPM app). It stores all the tool-specific data, as well as a list of all sensors that are found on the tool. Up to 128 sensors can be managed in one tool.

The attachment of the data part should ideally take place in the UT. The data part must be freely accessible to be able to press the query button (Check button) and tool change-over button (LOGIN button).



Possible installation position for data part



No free accessibility to the data part

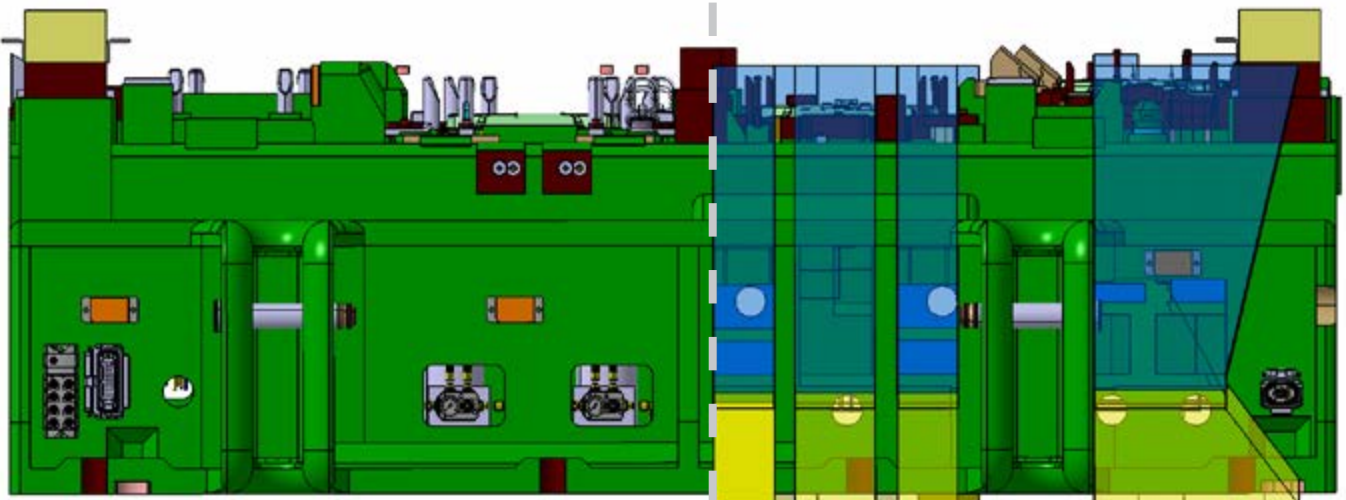

INSTALLATION OF WPM REPEATER

The WPM repeater collects the data from the sensors and data storage devices and forwards it to the WPM cloud software via WIFI or Ethernet. The software evaluates the data and initiates appropriate measures such as warning messages or power press stops.

In order to warranty continuous monitoring, the sensor signals must have good reception.

The repeater should, therefore, be placed so that there is a good wireless connection to the sensors in the tool.



The reception range of the repeater is between 25–50 m. The mounting of the repeater should be vertically. Wall mounting is therefore preferable to ceiling mounting. A power supply and possibly a network connection are required.

The best wireless coverage is achieved via a diagonally offset arrangement.

For monitoring the power press and for programming of the sensors, the repeater should be placed in the immediate vicinity of the tool (5–10 m).

NOTE:

**Installation in the control equipment cabinet is not possible due to the shielding of the metal box!
Do not mount the repeater inside the power press (not protected against splash water)!**

DISTRIBUTORS

Germany

PLZ 10000-19000

Außendienst Andreas Otto

Immenweg 3
16356 Ahrensfelde OT Eiche
M +49 170 739 00 64
a.otto@fibro.de

PLZ 20000-29000, 49000

Walter Ruff GmbH

Heerenholz 9
28307 Bremen
T +49 421 438 78-0
F +49 421 438 78-22
mail@praeziruff.de
www.praeziruff.de

PLZ 30000-31000, 37000-39000

Außendienst Stephan Hoffmann

Unter den Linden 22
38667 Bad Harzburg
M +49 171 971 90 05
s.hoffmann@fibro.de

PLZ 32000-34000, 48000-49000

Außendienst Partick Klee

Am Holleracker 1a
35232 Dautphetal
M +49 170 576 00 09
p.klee@fibro.de

PLZ 35000-36000, 57000, 60000-61000, 65000

Außendienst Ralf Feldmann

Wiesenstraße 23b
58339 Breckerfeld
M +49 151 12 59 01 59
r.feldmann@fibro.de

PLZ 42000, 44000-46000, 58000-59000

Außendienst Lars Jahncke

Flockertsberg 17
42653 Solingen
M +49 170 7637125
l.jahncke@fibro.de

PLZ 40000-42000, 47000, 50000-53000

Außendienst Hartwig Hennemann

Staubenthaler Höhe 79
42369 Wuppertal
M +49 175 29 659 30
h.hennemann@fibro.de

PLZ 63000-64000, 67000-69000, 76000-77000

Außendienst Markus Rössl

Johann-Strauß-Straße 16/1
74906 Bad Rappenau
M +49 160 97 25 23 93
m.roessl@fibro.de

PLZ 70000-73000, 88000-89000

Außendienst Meric Üven

Esslinger Straße 76
70736 Fellbach
M +49 170 5411416
m.ueven@fibro.de

PLZ 71000, 74000-75000, 97000

Außendienst Matthias Ehrenfried

Steigerwaldstraße 25
74172 Neckarsulm
M +49 171 864 95 52
m.ehrenfried@fibro.de

PLZ 72000, 77000-79000, 88000

Außendienst Matthias Jörg

In der Krautbündt 44
77656 Offenburg-Zunsweier
M +49 151 21 28 25 00
m.joerg@fibro.de

PLZ 80000-89000

Jugard + Künstler GmbH

Beta-Straße 10e
85774 Unterföhring
T +49 89 546 15 60
F +49 89 580 27 96
info@jk.de
www.jugard-kuenstner.de

PLZ 90000-97000

Jugard + Künstler GmbH

Weidentalstraße 45
90518 Altdorf bei Nürnberg
T +49 9187 936 69-0
F +49 9187 936 69-90
info@jk.de
www.jugard-kuenstner.de

PLZ 01000-09000, 98000-99000

Held Werkzeugmaschinen und Präzisionswerkzeug GmbH & Co.KG

Fasaneninsel 1
07548 Gera
T +49 365 824 91 0
F +49 365 824 91 11
info@held-wzm.de
www.held-wzm.de

International

AR **ARCINCO Industrial Ltda.**

Rua Oneda, 935 - Planalto
 CEP 09895-280 - São Bernardo do
 Campo - SP
 T +55-11-3463.8855
 F +55-11-4390.9155
 joyce@arcinco.com.br
 www.arcinco.com.br

AT **Rath & Co. Ges. m.b.H.**

Teiritzstrasse 3
 2100 Korneuburg
 T +43 2262 608 0
 F +43 2262 608 60
 office@rath-co.at
 www.rath-co.at

AU **Bruderer Presses Australia Pty. Ltd.**

Unit 4, 7 Dowling Place
 South Windsor NSW 2756
 Australia
 T +61 417681800
 brudsyd@optusnet.com.au

BA **WML Robert Bednjanec**

Vlaska 76
 10000 Zagreb
 T +385 984 16005
 robert.bednjanec@net.hr

BE **Schiltz s.a.**

Rue Nestor Martin 319
 1082 Bruxelles
 T +32 2 464 4830
 F +32 2 464 4839
 info@schiltz.be
 www.schiltz.be

BG **Bavaria 2002 EOOD**

Patriarh Evtimii 10
 5100 Gorna Orjachoviza
 T +359 618 64158
 F +359 618 64960
 bavaria2002@gorna.net
 www.bavaria2002.hit.bg

BR **ARCINCO Industrial Ltda.**

Rua Oneda, 935 - Planalto
 CEP 09895-280 - São Bernardo do
 Campo - SP
 T +55-11-3463.8855
 F +55-11-4390.9155
 joyce@arcinco.com.br
 www.arcinco.com.br

CA **FIBRO Inc.**

139 Harrison Ave.
 Rockford, IL 61104
 T +1 815 229 1300
 F +1 815 229 1303
 info@fibroinc.com
 www.fibro.com

CH **Außendienst Reinhard Schreiner**

Hasenbergstrasse 40
 6312 Steinhausen
 M +41 76 568 59 06
 r.schreiner@fibro.de

CL **CL OF Química SPA**

Parinacota 239, Quilicura
 Santiago, RM
 T +56 2 2249 06 78
 C +56 9 9449 95 22
 mcarrasco@ofquimica.cl
 www.ofquimica.cl

CN **联系LÄPPLE (Taicang) Industrial Technology Co., Ltd.**

Building No. 15 · Industrial Park No.
 103 Chenmenjing road · Chengxiang
 Town 215400 Taicang · Jiangsu
 Province
 P.R. China
 T +86 512 8060 7979
 info@fibro.cn
 www.fibro.com

CY **Militos Trading Ltd.**

P.O.B. 27297
 1643 Nicosia
 T +357 22 75 12 56
 F +357 22 75 22 11
 militos@cytanet.com.cy

CZ **Technicky konzultant Vladimír Tanecká**

Snezienkova 10228/12
 960 01 Zvolen
 M +421 905 32 94 56
 v.tanecka@fibro.de
 www.fibro.com

Technicky konzultant

Menousek Jaromir
 M +420 777 39 99 66
 j.menousek@fibro.de
 www.fibro.com

DK **EBI A/S**

Sylvestervej 7
 DK-2610 Roedovre
 T +45 4497 8111
 F +45 4468 0626
 salg@ebi.dk
 www.ebi.dk

DZ **Pneumacoupe Blida Boufarik**

86 Bld. Menad Mohamed
 Boufarik, 09400 Blida
 T +213 347 5655
 F +213 347 5655
 pneumacoupe@yahoo.fr

EE **Waldec Eesti OÜ**

Läike tee 2
 75312 Peetri alevik, Harju maakond
 T +371 27027956
 latvia@waldecgroup.com
 www.waldecgroup.com

EG **Smeco**

68, Abdel Rahman El Raffei St.
 11351-Heliopolis West, Cairo
 T +20 2 620 06 71
 F +20 2 620 06 74
 r.metwally@tedata.net.eg

ES **Consultor Técnico Comercial Jaime Estela**

Zona Central-Levante
 Aragón-Cataluña
 M +34 668 121 167
 j.estela@fibro.de

Consultor Técnico Erik Brok

Zona Noroeste · País Vasco
 M +34 668 137 676
 e.brok@fibro.de

FI **FI CLE Finland Oy**

Sähkötie 1
 62200 Kauhava
 T +358 207 519 600
 F +358 207 519 619
 info@cle.fi
 www.cle.fi

DISTRIBUTORS

International

FR FIBRO France Sarl

26, avenue de l'Europe
67300 Schiltigheim
T +33 3 90 20 40 40
F +33 3 88 81 08 29
info@fibro.fr
www.fibro.com

GB Bruderer UK Ltd.

Unit H, Cradock Road
LU4 OJF Luton, Bedfordshire
T +44 1582 563 400
F +44 1582 493 993
mail@bruderer.co.uk
www.bruderer-presses.com

GR Konstantinos Koutseris & Co. - MEK

Pyloy 100
10441 Athen
T +30 210 5220557
F +30 210 5221208
info@mek.com.gr
www.mek.com.gr

HK 联系LÄPPLE (Taicang) Industrial Technology Co., Ltd.

Building No. 15 · Industrial Park No.
103 Chenmenjing road · Chengxiang
Town 215400 Taicang · Jiangsu
Province
P.R. China
T +86 512 8060 7979
info@fibro.cn
www.fibro.com

HR WML Robert Bednjanec

Vlaska 76
10000 Zagreb
T +385 984 16005
wmlinternational77@gmail.com

HU Rath & Co. Ges. m.b.H.

Teiritzstraße 3
AT-2100 Korneuburg
T +43 2 262 608 0
F +43 2 262 608 60
office@rath-co.at
www.rath-co.at

ID FIBRO Asia Pte. Ltd.

9, Changi South Street 3, #07-04
Singapore 486361
T +65 65 43 99 63
F +65 65 43 99 62
info@fibro-asia.com
www.fibro.com

IE Bruderer UK Ltd.

Unit H, Cradock Road
LU4 OJF Luton, Bedfordshire
T +44 1582 563 400
F +44 1582 493 993
mail@bruderer.co.uk
www.bruderer-presses.com

IL A. J. Englander 1980 Ltd.

13 Harechev Street
Tel Aviv 6777146
T +972 3 537 36 36
F +972 3 537 33 25
info@englander.co.il
www.englander.co.il

IN FIBRO INDIA

PRECISION PRODUCTS PVT. LTD.
Plot No: A-55, Phase II, Chakan MIDC
Taluka Khed, Pune - 410 501
T +91-2135 67 09 03
M +91-98810 00273
info@fibro-india.com
www.fibro.com

IT Millutensil S.R.L.

Corso Buenos Aires, 92
20124 Milano
T +39 02 2940 4390
F +39 02 204 6677
info@millutensil.com
https://fibro.millutensil.com

KR FIBRO Korea Co. Ltd.

203-603, Bucheon Technopark
Ssangyong 3 · 397, Seokcheon-ro,
Ojeong-gu, Bucheon-si,
Gyeonggi-do
T +82 32 624 0630
F +82 32 624 0631
fibro_korea@fibro.kr
www.fibro.com

LI Außendienst Reinhard Schreiner

Hasenbergstrasse 40
6312 Steinhausen
M +41 76 568 59 06
r.schreiner@fibro.de

LT CLE Baltic Oū

Pramones gatve 94-7
11115 Vilnius, Lithuania
T +370 663 56309
F +370 520 40914
latvia@waldecgroup.com
www.clebaltic.com

LV Waldec Latvia SIA

Atmodas iela 19-239, Jelgava
LV-3007, Latvia
T +371 27027956
latvia@waldecgroup.com
www.waldecgroup.com

MA Chiba Industrie

Bd. Mohamed Bouziane Lot 103,
Hay My Rachid
20670 Casablanc
T +212 523 31 40 16/17/19
F +212 523 30 39 85
h.hind@chibaindustrie.com

MX FIBRO Inc.

139 Harrison Ave.
Rockford, IL 61104
T +1 815 229 1300
F +1 815 229 1303
info@fibroinc.com
www.fibro.com

MY FIBRO Asia Pte. Ltd.

9, Changi South Street 3, #07-04
Singapore 486361
T +65 65 43 99 63
F +65 65 43 99 62
info@fibro-asia.com
www.fibro.com

NL Jeveka B.V.

Platinaweg 4
1362 JL Almere Poort
T +31 36 303 2000
info@jeveka.com
www.jeveka.com

International

NZ APS Tooling Ltd.

13E Onslow Avenue
Papatoetoe, Auckland 2104,
New Zealand
T +64 9 579 2208
F +64 9 579 2207
info@apstools.co.nz

PE Brammertz Ingenieros SA

Av. José Pardo 182 Of.902
Miraflores 15074
Lima, Perú
T +51 1 208 4600
F +51 1 445 1931
import@brammertz.com
www.brammertz.com

PL FIBRO Polska Sp. z o.o.

Aleja Armii Krajowej 220
Pawilon AG piętro 3
43-316 Bielsko-Biała
T +48 6980 57720
info@fibro.pl

PT FERROMETAL, UNIPESSOAL, LDA.

Estrada Manuel Correia Lopes
Parque Empresarial Progresso-
Armazém 1
Polima
2785-718 S. Domingos de Rana
T +351 214 447 160
F +351 214 447 169
ferrometal@ferrometal.pt

RO Reprezentant Vânzari

Daniel Andrei Sibisan
Strada Hărmanului 21
Bl. 31, SC.D. Ap.8
RO-500228, Braşov
T +40 744 44 05 83
F +40 368 78 00 08
d.sibisan@fibro.de
www.fibro.com

RS Tesic

Partisanska 12/a-II
11090 Beograd
T +381 11 2338 362
F +381 11 2338 362
atesic@verat.net

RU CL Engineering & Co. Ltd.

ul. Sofyiskaya 66
192289 S. Petersburg
T +7 812 575 1592
F +7 812 324 7388
info@cleru.ru
www.cleru.ru

RU OOO VTF Instrumsnab

ul. Topolinaya 9A
445047 Togliatti
T +7 8482681424
F +7 8482681452
office@instrumsnab.com
www.instrumsnab.ru

SA Modern Zone Trading Company

Al Qandeel Street Makkah
Al Aziziyah Dist , P.O Box 65386
Jeddah 21556
T +966 53 953 03 73
fibro.sa@gmail.com
www.modernzonetrading.com

SE Lideco AB

Verkstadsvägen 4
51463 Dalstorp
T +46 321 53 03 50
F +46 321 603 77
info@lideco.se
www.lideco.se

SG FIBRO Asia Pte. Ltd.

9, Changi South Street 3, #07-04
Singapore 486361
T +65 65 43 99 63
F +65 65 43 99 62
info@fibro-asia.com
www.fibro.com

SI Tehnični svetovalec Jozef Majcen

Poslovni prostor št. 1 v
Poslovnem Centru Mops
Mariborska c. 83 · 2312 Orehova vas.
T +386 820 52740
M + 386 41 387 889
j.majcen@fibro.de
www.fibro.com

SK Technicky konzultant Vladimír Tanecká

Snezienkova 10228/12
960 01 Zvolen
M +421 905 32 94 56
v.tanecka@fibro.de
www.fibro.com

TH FIBRO Asia Pte. Ltd.

9, Changi South Street 3, #07-04
Singapore 486361
T +65 65 43 99 63
F +65 65 43 99 62
info@fibro-asia.com
www.fibro.com

TR Ender Kesici ve Teknik Takımlar

Sanayi Ticaret A.Ş.
Eğitim Mh. Kasap İsmail Sok.
Sadıkoğlu Plaza 5 No: 11G/3
Kadıköy 34722, İstanbul
T +90 216 330 6005
F +90 216 330 6006
info@enderltd.com
www.enderltd.com

TW SunNan Enterprises Co. Ltd.

2F, No. 7, Alley 6, Lane 235
Pao-Chiao Road
Hsin-Tien City · Taipei
T +886 22917 6454
F +886 22911 0398
sun-ss@umail.hinet.net

US FIBRO Inc.

139 Harrison Ave.
Rockford, IL 61104
T +1 (815) 229-1300
F +1 (815) 229-1303
info@fibroinc.com
www.fibro.com

ZA Herrmann & Herrmann Pty. Ltd.

43 Ferero Street. Edenglen.
Edenvale 1609
T +27 11 828 01 00
F +27 11 828 60 21
hermstools@mweb.co.za
www.hermstools.com

Further information at
www.fibro.de/en/wpm/



FIBRO GMBH

Business Unit Standard Parts
August-Läpple-Weg
74855 Hassmersheim
GERMANY
T +49 6266 73-0
info@fibro.de
www.fibro.com

THE LÄPPLE GROUP

LÄPPLE AUTOMOTIVE
FIBRO
FIBRO LÄPPLE TECHNOLOGY
LÄPPLE AUS- UND WEITERBILDUNG