



# Maintenance instructions

## Gas springs with increased spring force

2487.12.00350. - . 20000.  
2487.12.33.00350. - .06600.  
2487.82.01000.  
2488.13.00750. - .20000.

Document: Maintenance instructions  
Document number: 2.7513.04.1214.01000  
Revision status: 04.1214

Valid for: Gas springs

Revision				
Date	Version	Chapter	Reason	Commissioned party
09/2012	03.1011	All	New version	N. Reinmuth
12/2014	04.1214	2	Supplementation	N. Reinmuth

This document was created by  
FIBRO GmbH  
Business Area Standard Parts  
August-Läpple-Weg  
D-74855 Hassmersheim

© FIBRO GmbH

All rights in this document are subject to the copyright by FIBRO GmbH. This document may not be copied or reproduced neither as a whole nor partially without prior written consent by FIBRO GmbH. The document is only aimed at the user of the described components and may not be passed on to uninvolved third parties - especially competitors.

---

## 1 Safety

The statements contained in this document only apply to the maintenance of the stated gas springs and are only for the use by trained and authorised staff.

Staff has to have the necessary training, experience and product knowledge as well as specialist tools in order to carry out maintenance work correctly.

Staff has to have fully read and understood this document prior to carrying out any maintenance work.

Replacement of spare parts without special training or knowledge of the maintenance instructions and without the specialist tools can be dangerous and may lead to accidents causing severe injuries or even death.

Most accidents during maintenance occur due to disregarding the basic safety regulation.

Noticing a potential danger can prevent accidents from happening. Safety information in this document warn about potential risks.

FIBRO GmbH can not foresee all situations which may potentially cause risks. The warnings in this document are therefore not all encompassing.

If a work material, an act, a work method or work technique is used which has not been specifically suggested by FIBRO GmbH, then the user has to ensure the safety for himself and other persons.

The information, descriptions and illustrations in this documents are based on the information on the basis of information which was available at the point of creation of this document.

Illustrations show examples of a potential gas spring and are not to scale.

Descriptions, tightening torques, operating pressures, measuring methods, illustrations and other points are subject to change at any time. The changes can have an influence on the component's properties. Prior to starting any work, obtain the currently available information.

The signal boards used in these instructions have the following meanings:

 <b>WARNING</b>	<b>WARNING</b> indicates a hazardous situation which, if not avoided, could result in death or serious injury.
<b>NOTICE</b>	<b>NOTICE</b> is used to address practices not related to personal injury.

**! WARNING****Filled gas springs are subject to high internal pressure.**

Empty nitrogen completely before carrying out any repairs. Open valve carefully and only slightly to do so. Wear safety glasses. Eye injuries possible due to escaping nitrogen.

Never bend over the valve after removing blanking plug. Never direct the filling opening at a person. Only unscrew valve once nitrogen has completely emptied. Possible injuries due to valve blowing off.

If assembled incorrectly, there is a risk of parts being hurled outwards. Adhere to exact installation position of spare parts. Never direct the piston rod at a person. Injuries due to parts blowing off.

**Use of wrong spare parts**

Installation of wrong spare parts leads to a loss in safety. Parts may be ejected due to the internal pressure after filling with nitrogen. Always ensure prior to the repair that the right spares kit is used. PED-gas springs have a separate spares kit. Individual components are not compatible to the previous version. For the PED-gas springs the cylinder, installation kit and piston rod are marked at their upper end by grooves. Adhere to marking. PED-components and non-PED-components must not be mixed. Injuries due to parts blowing off.

**NOTICE****Damages during repair**

Always use protective jaws when clamping a gas spring into a vice. Ensure a clean environment.

Grooves, bumps or other damages can cause leakages. Never exercise undue force to the gas spring during repair. Protect against damages.

Let nitrogen flow in slowly during the filling process. The valve of the gas spring can be damaged.

For the filling process, only use pure nitrogen N<sub>2</sub> of Grade 5.0 purity or higher.

Highest permissible filling pressure: 150 bar (2175 psi).

For gas spring 2487.12.00350. / 2487.12.33.00350: 180 bar (2610 psi).

For safe maintenance further, applicable documents are necessary. The information in these documents have to be adhered to.



Gas spring operating instructions



Safety data sheet "Exchange of spare parts"



Operating instructions filling and control fitting.

## 2 Maintenance

### 2.1 Inspection

#### 2.1.1 Check gas pressure

**NOTICE** Use the resources listed below for the check. The resources can be obtained from FIBRO GmbH. Damage to the gas pressure spring if other resources are used.

Item	Name	Article number
[A]	Filling and control fitting	2480.00.32.21
[B]	Filling adapter G1/8" (For gas springs with G1/8" threaded filling connection. In the case of gas springs with M6 threaded filling connection, the filling and control fitting can be screwed directly into the filling opening.)	2480.00.32.11
[C]	Filling hose	2480.00.31.02
	Bottle pressure regulator (optional)	2480.00.32.07

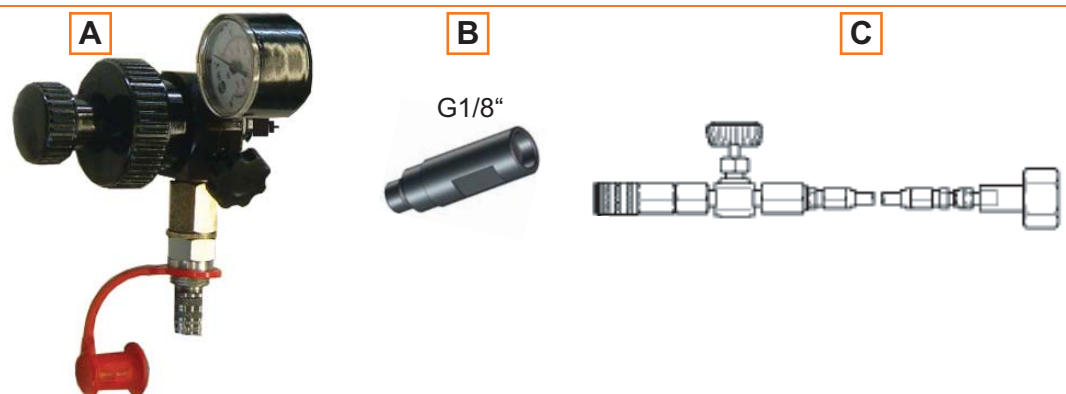

Adhere to operating instructions for the filling and control fitting 2480.00.32.21.

## 2.1 Inspection

**NOTICE** For gas springs with G1/8" threaded filling connection. In the case of gas springs with M6 threaded filling connection, the filling and control fitting can be screwed directly into the filling opening.

1. Filling and control fitting to be prepared.
  - ▶ Small turn knob (a) to be turned left until it arrests. This moves the tripping pin (b) into the retracted position.
  - ▶ Outlet valve (c) to be connected.

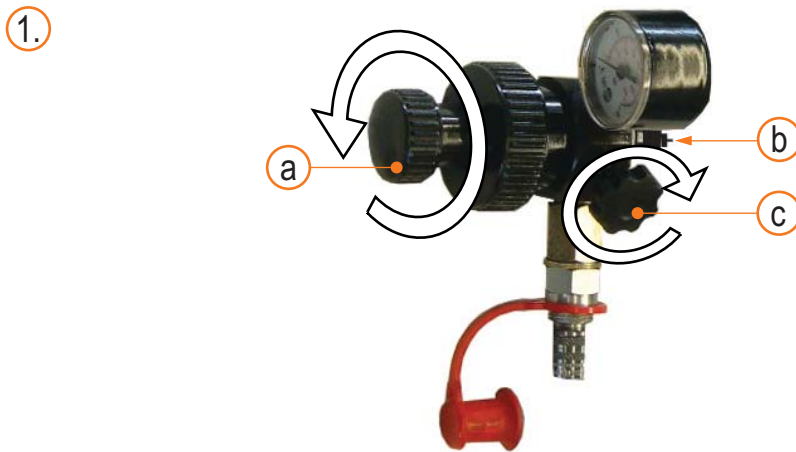

2. Remove the blanking plug above the filling opening of the gas spring with an Allen key (M6 - 3 mm; G1/8" - 5 mm).
3. Unscrew and remove set screw.
4. Filling adapter to be screwed into the filling opening of the gas spring. Tighten hand-tight.
5. Filling and control fitting to be put on the filling adapter. Screw on the large turn knob by turning it.
6. Screw in the small turn knob. The tripping pin opens the valve. Caution! Do not screw in the tripping pin too far. This could damage the valve.
7. Read filling pressure on manometer display.

- i** The permissible filling pressure is imprinted on the gas spring. Nitrogen has to be added if filling pressure is too low (see chapter 2.4 „Fill with nitrogen“ on page 24).

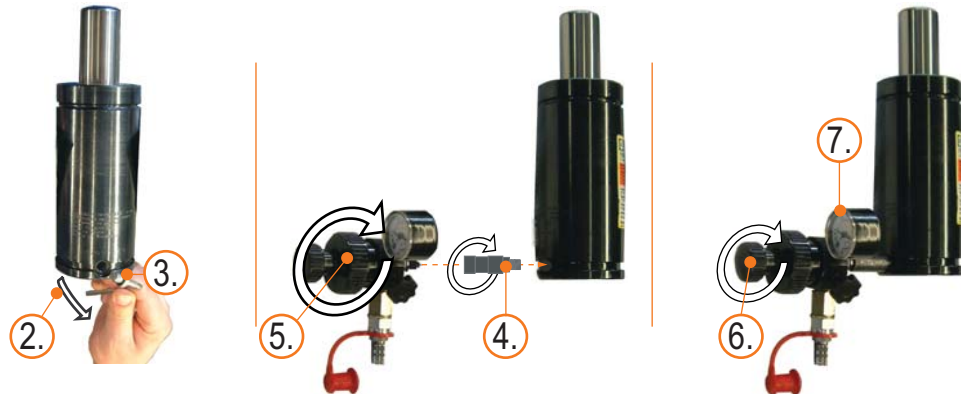

8. After the check, open the small control knob. The detent pin goes back into retracted position and closes the valve.
9. Open control knob at discharge valve and vent filling and control fitting.
10. Unscrew filling and control fitting by turning the large turning knob from the filling adapter.
11. Filling adapter to be unscrewed.
12. Blanking plug to be inserted into filling opening of the gas spring. Tighten with a torque of 2 Nm (1,5 lb-ft) for M6; 15 - 18 Nm (11-13 lb-ft) for G1/8".

- i** The set screw has a sealing function and has always to be assembled.



## 2.2 Repair

## 2.2 Repair

**NOTICE** We do not recommend making repairs to the spring types 2487.12.02400.016 and 2487.12.33.02400.016 as the circlip on these gas springs is very difficult to remove.

## 2.2.1 Required spare parts, tools and tool kits.

-  There are different spare part sets available depending on the installed spring. Prior to the repair, the correct spare kit set has to be available for the gas spring.

Spring type	Spares kit
2487.12.00350. 2487.12.33.00350.	2487/12/00350
2487.12.00500. 2487.12.33.00500.	2487/12/00500
2487.12.00750. 2487.12.33.00750.	2487/12/00750
2488.13.00750.	2488.13.00750
2487.12.01000. 2487.12.33.01000.	2487/12/01000
2487.82.01000.	2487/82/01000
2488.13.01000.	2488/13/01000
2487.12.01500. 2487.12.33.01500.	2487/12/01500
2488.13.01500.	2488.13.01500
2487.12.02400. 2487.12.33.02400.	2487/12/02400
2488.13.02400.	2488/13/02400
2487.12.04200. 2487.12.33.04200.	2487/12/04200
2488.13.04200.	2488/13/04200
2487.12.06600. 2487.12.33.06600.	2487/12/06600
2488.13.06600.	2488/13/06600
2487.12.09500.	2487/12/09500
2488.13.09500.	2488/13/09500
2487/12/20000.	2487/12/20000
2488.13.20000.	2488.13.20000

A spares kit consists of:

(1)	Blanking plug G1/8" (248.00.43.1) Blanking plug M6 (2480.00.41.2)	(2)	Valve VG5 (248.00.41) Valve M6 (2480.00.41.1)
(3)	Circlip	(4)	Dirt protection ring
(5)	Installation kit	(6)	Special oil 35ml (248.00.50)
(7)	Sticker	(8)	Special grease 20ml (248.00.51.0020)



**NOTICE** Only use genuine spare parts from FIBRO GmbH. All spare parts included in the spare parts kit must always be replaced completely. Damage to the gas pressure spring if other spare parts are used.

## 2.2 Repair

**NOTICE** Use the resources and special tools listed below for repairs. The resources and tools can be obtained from FIBRO GmbH. Damage to the gas pressure spring if other resources and tools are used.



Adhere to operating instructions for the filling and control fitting 2480.00.32.21.

Tools:

Item	Name	Article number
[A]	Filling and control fitting	2480.00.32.21
[B]	Filling adapter G1/8" (For gas springs with G1/8" threaded filling connection. In the case of gas springs with M6 threaded filling connection, the filling and control fitting can be screwed directly into the filling opening.)	2480.00.32.11
[C]	Filling hose	2480.00.31.02
	Bottle pressure regulator (optional)	2480.00.32.07

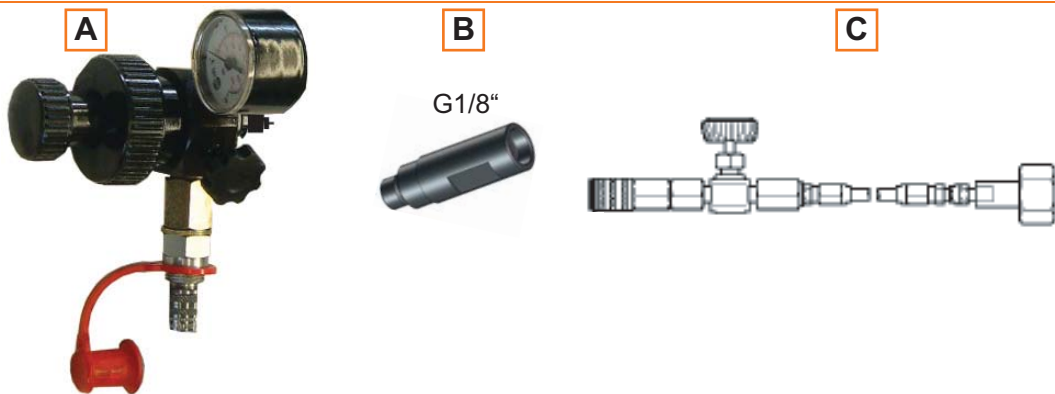

Tool kits:

Item	Name	
[D]	Complete tool kit (2480.00.50.11), consisting of	
(1)	T-tool M6 / M8	(2) T-tool M16
(3)	Assembly sleeve	(4) Valve pliers
(5)	Circlip pliers	(6) Valve tool G1/8" Valve tool M6

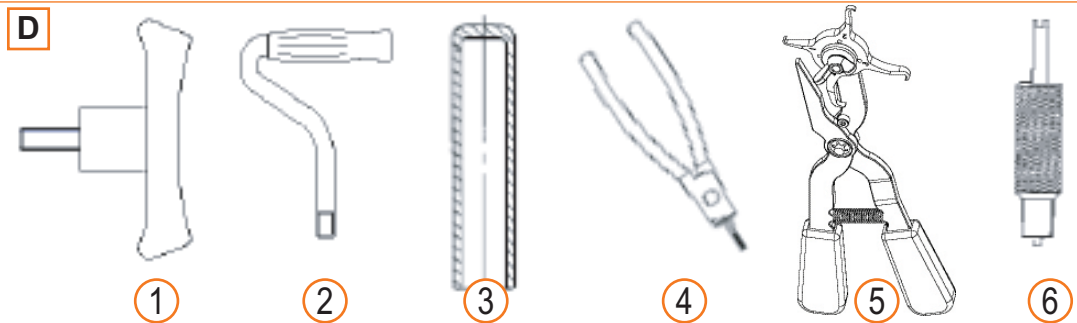

- i** An Allen key is necessary to open the blanking plug. A torque wrench with an Allen socket is necessary to tighten the blanking plug.
- ▶ 3 mm wrench width for M6 blanking plug
  - ▶ 5 mm wrench width for G1/8" blanking plug

## 2.3 Replacement of spare parts

## 2.3 Replacement of spare parts

## 2.3.1 Dismantle gas spring

1. Insert protective jaws into vice.
2. Clamp gas spring in tilted position (approx. 30°) into vice. Piston rod slopes downwards.
3. Put container under gas spring to catch discharging oil.
4. Remove the blanking plug above the filling opening of the gas spring with an Allen key (M6 - 3 mm; G1/8" - 5 mm).
  - ▶ 3 mm wrench width for M6 blanking plug
  - ▶ 5 mm wrench width for G1/8" blanking plug
5. Unscrew and dispose off blanking plug.

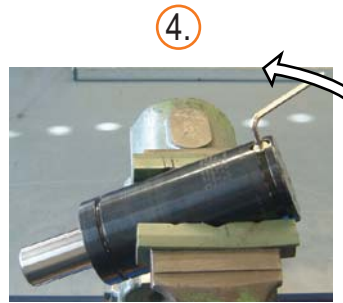
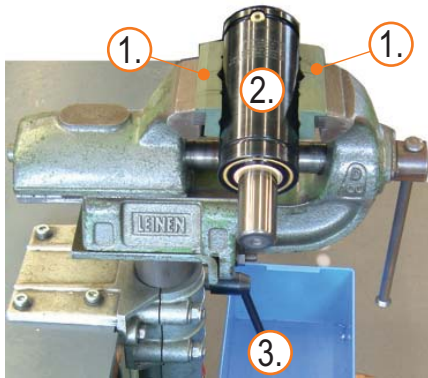

## 2.3 Replacement of spare parts

**⚠ WARNING** Nitrogen escaping. High pressure. Carefully open the valve. Wear safety goggles. Nitrogen that escapes can cause eye injuries.

6. Thread end of the valve tool has to be inserted so far into the filling opening until the valve opens.
7. Let nitrogen escape slowly and completely.
8. After emptying, use the other end of the valve tool to unscrew the valve entirely from the thread.
9. Remove valve from the filling opening using the valve pliers.

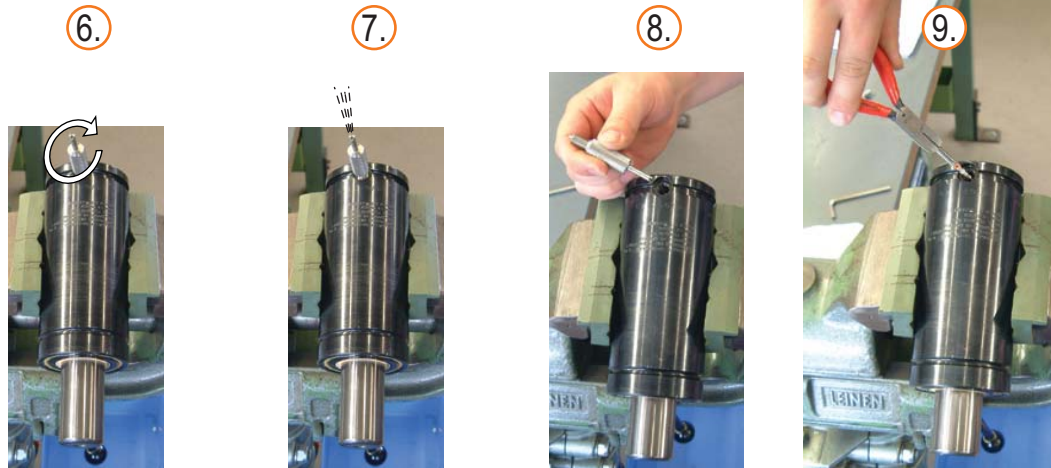

## 2.3 Replacement of spare parts

10. Put gas spring onto work desk. Use drip tray.
11. Put assembly sleeve over the piston rod.
12. Using a rubber mallet, drive installation kit so far into the cylinder until the circlip (a) becomes visible.
13. Remove dirt protection ring (b).

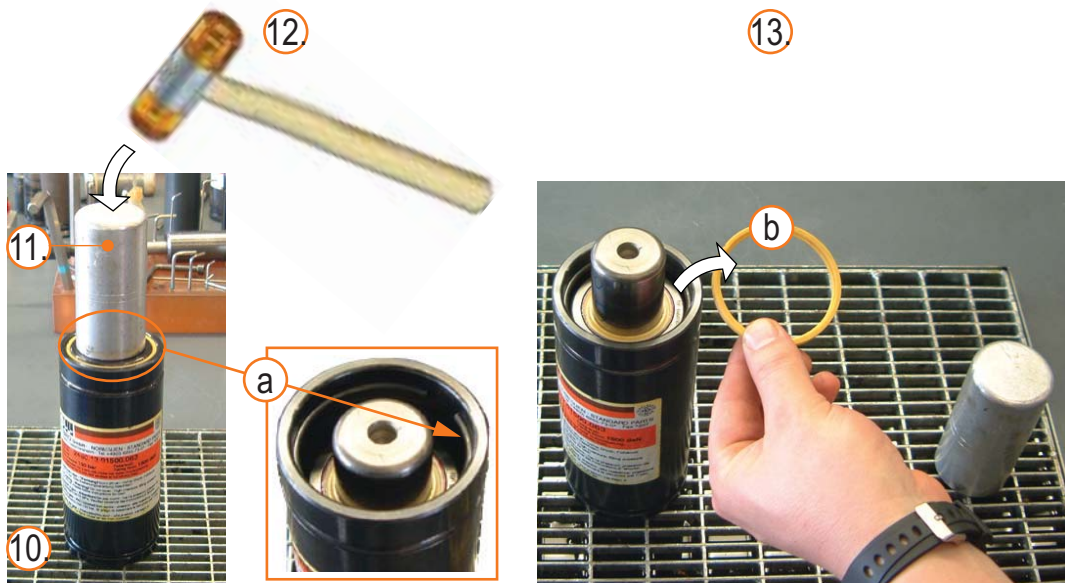

## 2.3 Replacement of spare parts

14. Clamp gas spring vertically into the vice.

**⚠ WARNING** Jumping out circlip. Wear safety glasses. Eye injuries.

15. Remove circlip (a) with circlip pliers.

16. Re-clamp gas spring in vice. Tilted position (about 30°). Piston rod tilts upwards.

17. Insert T-tool into piston rod.

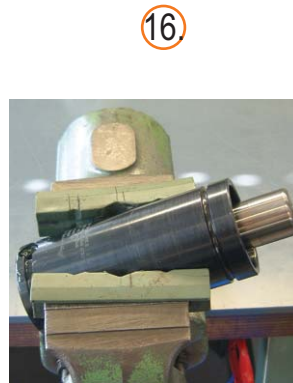
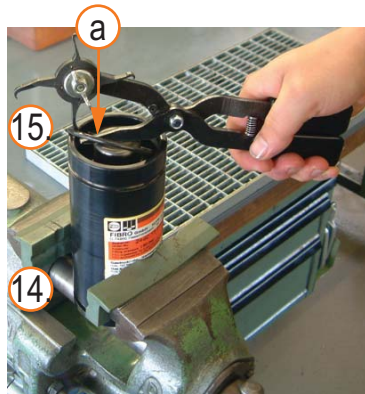

18. Draw the piston rod and installation kit from the cylinder.

19. Unscrew T-tool from the piston rod.

20. Take cylinder from vice and pour out oil.



18.

20.



## 2.3 Replacement of spare parts

21. Pull out piston rod (a) from installation kit (b).

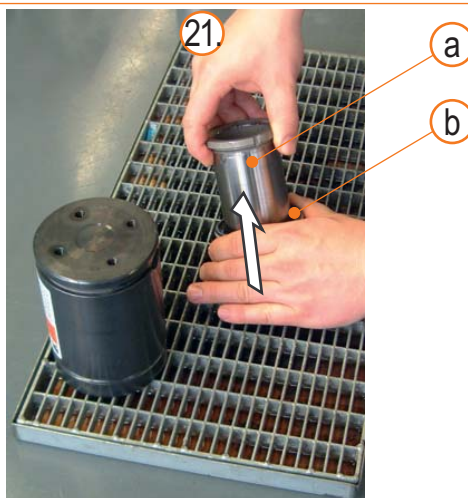

22. Set the cylinder and piston rod aside for later use.

23. Dispose of the installation kit, circlip and dirt protection ring.

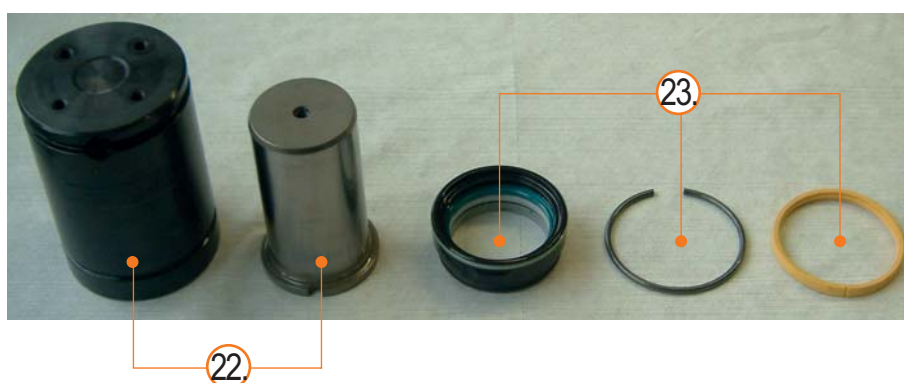

## 2.3 Replacement of spare parts

**2.3.2 Clean and check components.**

1. Clean the piston rod and cylinder.
2. Check piston rod and cylinder.

**NOTICE** Leakage, damage to equipment. Even minor damage to the cylinder or piston rod can result in leaks. A careful inspection is required. The installation of damaged parts is not permitted. Damaged parts must be replaced.

The following illustration shows some examples of damaged parts.



## 2.3 Replacement of spare parts

## 2.3.3 Assemble gas spring

**NOTICE** Jamming, damage to equipment. Make sure that the correct piston rod is installed. To check this, place the unmounted piston rod in the cylinder. The upper end of the piston rod and the cylinder have to be in alignment.

1. Unpack spares kit.
2. Grease the piston rod.
3. Lightly oil the inner seals and socket on the new installation kit with the special oil.
  - ▶ For spring types 2487.12.06600. through 2487.12.20000. as well as 2487.12.33.06600., 2488.13.06600. and 2488.13.09500, also fill the inner hollow space (a) with grease.

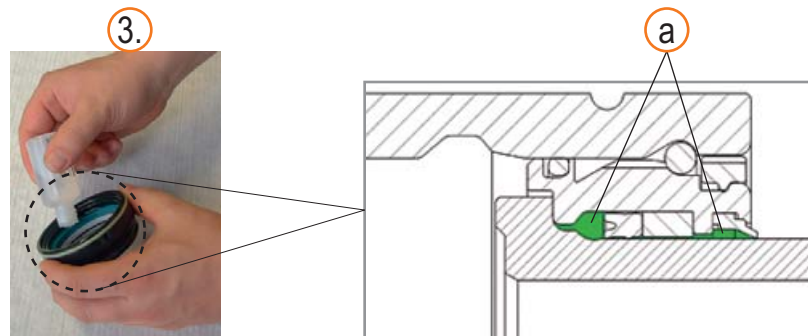

## 2.3 Replacement of spare parts

**⚠ WARNING** Faulty assembly. Faulty assembled installation kit can release the circlip during subsequent filling with nitrogen. Piston rod can be ejected. Please adhere to markings on the installation kit. Injuries due to parts blowing off.

4. Place the installation kit on the piston rod. The grey wiper ring should be facing up.



5. Slightly oil outer seals on the new installation kit.

**i** Before filling the special oil, position the cylinder in such a way that the oil cannot flow out of the filling opening.

6. Fill the special oil into the cylinder (for oil quantity, see table).



## 2.3 Replacement of spare parts

Spring type	Stroke	Oil	Grease
2487.12.00350.	10 - 16 mm	2 ml	--
2487.12.33.00350.	19 - 38 mm	3 ml	--
	50 - 100 mm	4 ml	--
2487.12.00500.	10 - 16 mm	2 ml	--
2487.12.33.00500.	19 - 38 mm	3 ml	--
	50 - 100 mm	4 ml	--
2487.12.00750.	all strokes	5 ml	--
2487.12.33.00750.			--
2488.13.00750.	all strokes	8 ml	yes
2487.12.01000.	all strokes	7 ml	--
2487.12.33.01000.			
2487.82.01000.	all strokes	7 ml	--
2488.13.01000.	all strokes	10 ml	yes
2487.12.01500.	13 - 25 mm	15 ml	--
2487.12.33.01500.	32 - 125 mm	20 ml	--
2488.13.01500.	all strokes	25 ml	yes
2487.12.02400.	16 - 38 mm	20 ml	--
2487.12.33.02400.	50 - 125 mm	25 ml	--
2488.13.02400.	all strokes	45 ml	yes
2487.12.04200.	all strokes	30 ml	--
2487.12.33.04200.			
2488.13.04200.	all strokes	50 ml	yes
2487.12.06600.	all strokes	70 ml	yes
2487.12.33.06600.			
2488.13.06600.	all strokes	70 ml	yes
2487.12.09500.	all strokes	80 ml	yes
2488.13.09500.	all strokes	80 ml	yes
2487.12.20000.	all strokes	120 ml	yes
2488.13.20000.	all strokes	80 ml	yes

## 2.3 Replacement of spare parts

7. Insert piston rod with the installation kit into the cylinder.
- i** Ensure correct position of outer O-ring (a).
8. Put assembly sleeve over the piston rod.
9. Using a rubber mallet, drive the installation kit into the cylinder until the groove for the circlip (b) becomes visible.

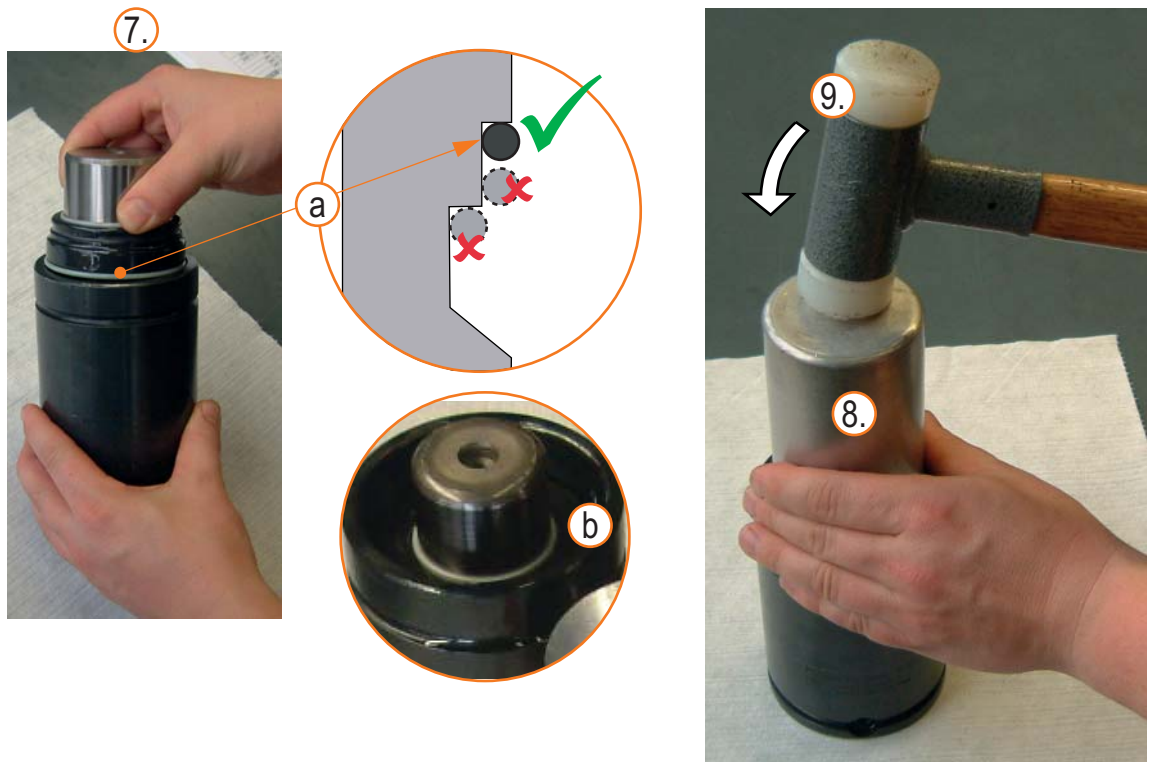

## 2.3 Replacement of spare parts

10. Align circlip into the groove.

- ▶ First insert one end of the circlip into the groove (a) and then hold with thumb.
- ▶ Then drive the ring downwards (b) until it comes to a rest in the groove making a clicking sound.

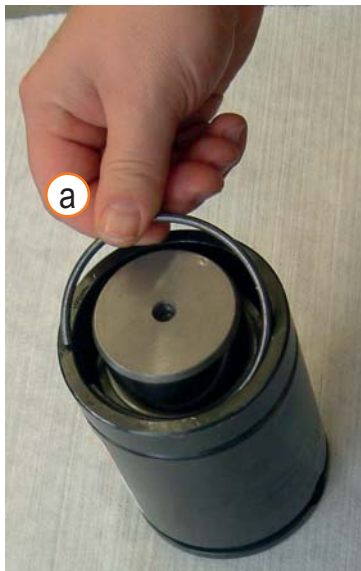

10.

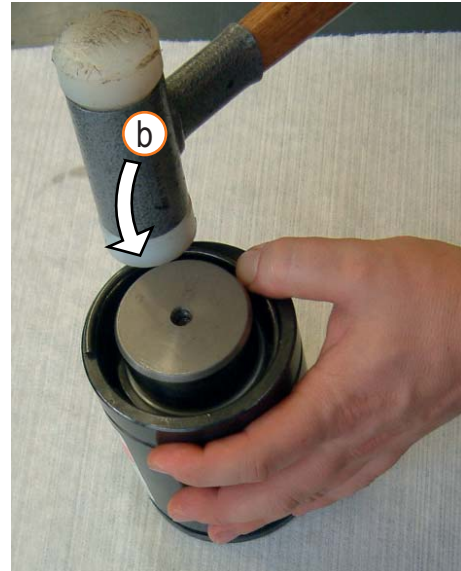

11. Clamp gas spring in tilted position (approx. 30°) into vice. Piston rod slopes downwards.

12. Insert T-tool into piston rod.

13. Pull out piston rod. The installation kit has to align with the upper end of the cylinder. If the installation kit does not align with the upper end of the cylinder, then the assembly is faulty.

14. Unscrew T-tool from the piston rod.

15. Insert valve into the filling opening and tighten by hand with valve tool.

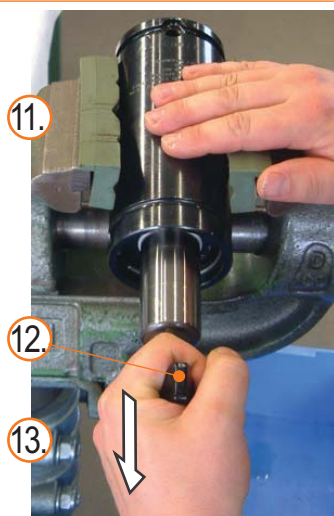

## 2.3 Replacement of spare parts

16. Put gas spring onto work desk.
17. Fill gas spring with nitrogen (see chapter 2.4 „Fill with nitrogen“ on page 24).
18. Slightly grease dirt protection ring and insert onto cylinder.
19. Press down dirt protection ring.

**i** The dirt protection ring prevents dirt from entering the gas spring and always has to be installed.

20. Remove old label from cylinder.

21. Stick provided new label onto cylinder and insert nominal stroke at the label.

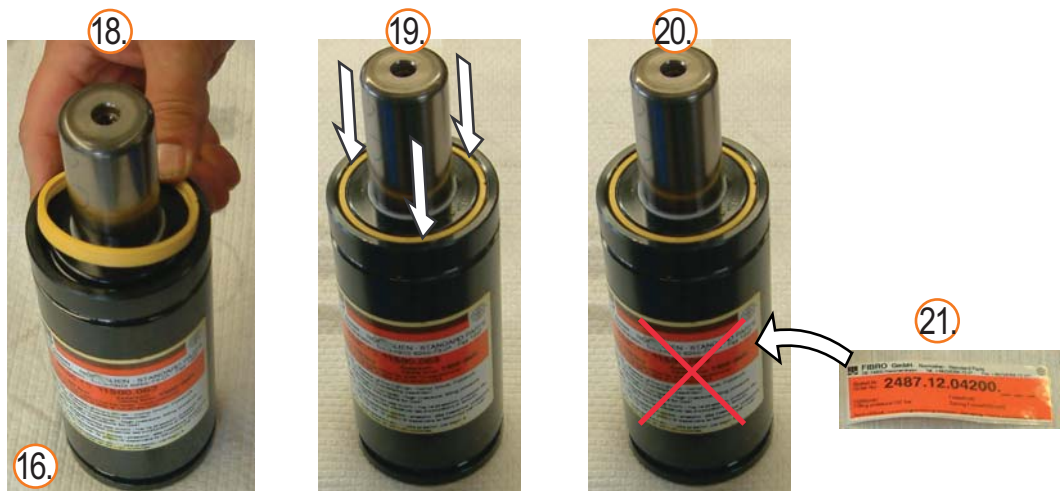

## 2.4 Fill with nitrogen

## 2.4 Fill with nitrogen

**NOTICE** Use the resources listed below for filling. The resources can be obtained from FIBRO GmbH. Damage to the gas pressure spring if other resources are used.

Item	Name	Article number
[A]	Filling and control fitting	2480.00.32.21
[B]	Filling adapter G1/8" (For gas springs with G1/8" threaded filling connection. In the case of gas springs with M6 threaded filling connection, the filling and control fitting can be screwed directly into the filling opening.)	2480.00.32.11
[C]	Filling hose	2480.00.31.02
	Bottle pressure regulator (optional)	2480.00.32.07

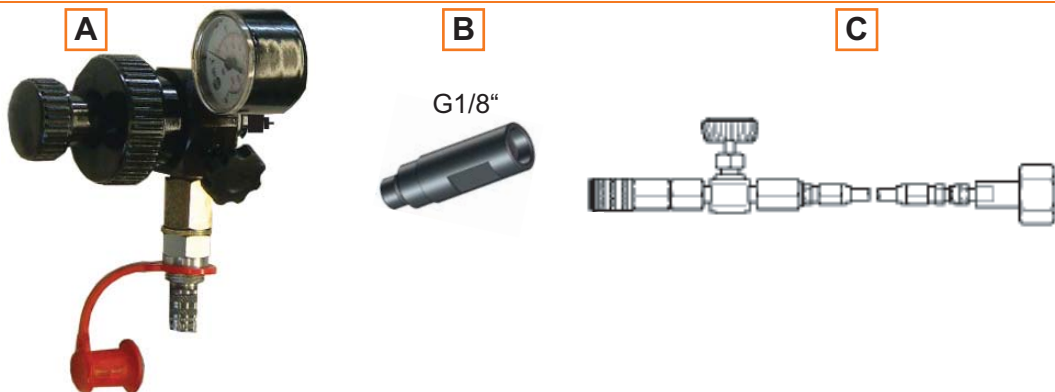

Adhere to operating instructions for the filling and control fitting 2480.00.32.21.

**NOTICE** For gas springs with G1/8" threaded filling connection. In the case of gas springs with M6 threaded filling connection, the filling and control fitting can be screwed directly into the filling opening.

1. Filling and control fitting to be prepared.
  - ▶ Small turn knob (a) to be turned left until it arrests. This moves the tripping pin (b) into the retracted position.
  - ▶ Outlet valve (c) to be connected.

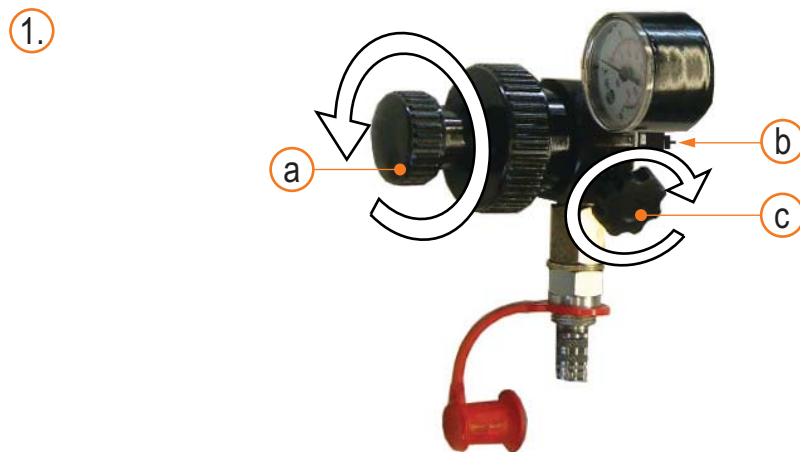

2. Filling adapter to be screwed into the filling opening of the gas spring. Tighten hand-tight.
3. Filling and control fitting to be put on the filling adapter. Screw on the large turn knob by turning it.
4. Shut-off valve has to be closed at the filling hose.
5. Screw the threaded connection of the filling hose to the nitrogen bottle.

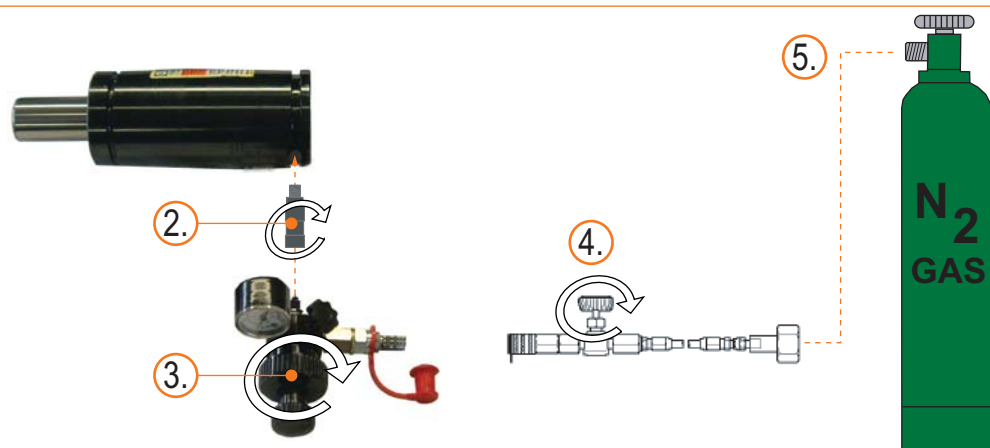

## 2.4 Fill with nitrogen

6. Fit bayonet catch of the filling hose onto the filling and control fitting.
7. Nitrogen bottle has to be opened at the turn knob of the bottle valve.

**NOTICE** Damage to the valve in the gas pressure spring. Slowly open the shut-off valve on the filling hose. Carefully allow nitrogen to flow in.

8. Shut-off valve has to be opened slowly at the filling hose. Manometer (b) shows the filling pressure.

**i** The permissible filling pressure (a) is imprinted on the gas spring.

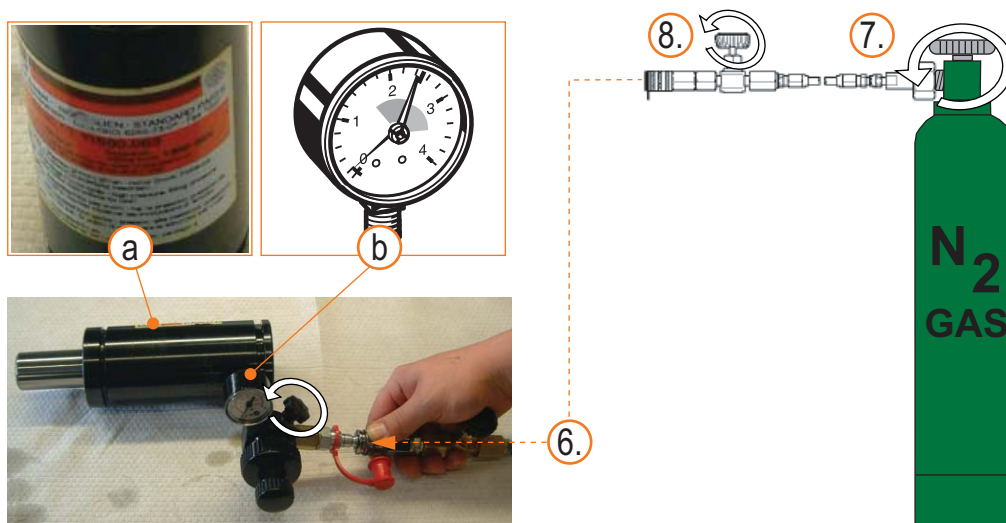

9. After the filling pressure has been achieved close the shut-off valve at the filling hose.
10. Close nitrogen bottle at the control knob of the bottle valve.
11. Shut-off valve has to be opened slowly at filling hose.
12. Discharge valve has to be opened at the filling and control fitting.
  - ▶ Pressure and remaining nitrogen escape from the filling and control fitting and filling hose.
13. Release and unscrew the threaded connection of the filling hose from the nitrogen bottle.
14. Remove filling hose at the bayonet catch from the filling and control fitting.
15. Unscrew filling and control fitting by turning the large turning knob from the filling adapter.
16. Filling adapter to be unscrewed.

## 2.4 Fill with nitrogen

17. Clamp gas spring in tilted position (approx. 30°) into vice. Piston rod slopes downwards.

**⚠ WARNING** Nitrogen escaping. Never bend over the valve of the gas pressure spring. Wear safety goggles. Risk of injury.

18. Check if nitrogen escape from the valve of the gas spring.

**i** If oxygen escapes, the valve needs to be replaced (removal see chapter 2.3.1 ; installation see chapter 2.3.3 ).

19. Blanking plug to be inserted into filling opening of the gas spring. Tighten with a torque of 2 Nm (1,5 lb-ft) for M6; 15 - 18 Nm (11-13 lb-ft) for G1/8".

- ▶ 3 mm wrench width for M6 blanking plug
- ▶ 5 mm wrench width for G1/8" blanking plug

**i** The set screw has a sealing function and has always to be assembled.



**Standard Parts**

**FIBRO GmbH** **DE**  
August-Läpple-Weg  
74855 Hassmersheim  
T +49 6266 73-0  
F +49 6266 73 237  
info@fibro.de

FIBRO France Sarl **FR**  
19/21, rue Jean Lolive  
93170 Bagnolet  
T +33 1 43 62 18 81  
F +33 1 48 59 17 47  
info@fibro.fr

FIBRO Inc. **US**  
139 Harrison Avenue  
Rockford, IL 61104  
T +1 815 2 29 13 00  
F +1 815 2 29 13 03  
info@fibroinc.com

FIBRO Asia Pte. Ltd. **SG**  
121 Genting Lane  
2nd Floor  
Singapore 349572  
T +65 68 46 33 03  
F +65 68 46 33 02  
info@fibro-asia.com

FIBRO INDIA **IN**  
STANDARD PARTS PVT. LTD.  
Antaral Society, Sanganna Dhotre Marg.  
Ganeshkhind Road  
Pune - 411 016  
T +91 20 25 65 62 39  
F +91 20 25 65 64 87  
info@fibro-india.com

FIBRO (SHANGHAI) **CN**  
STANDARD PARTS CO.,LTD.  
No.1, Lane 1388, Xiechun Road,  
Jiading District, 201804 Shanghai  
T +86 21 60 83 15 89  
F +86 21 60 83 15 99  
info@fibro-china.com

FIBRO KOREA CO. LTD. **KR**  
Sanggong-Building 401 HO  
Gojan-Dong, Namdong-Gu  
632-1 Incheon-City  
T +82 32 821 0130~1  
F +82 32 821 0030  
fibro@chol.com