



USER'S GUIDE

**Filling and control fitting**

**2480.00.32.21**

**Filling hose**

**2480.00.31.02**

**Cylinder pressure regulator**

**2480.00.32.07.**

precision is our standard

# User's Guide

## Filling and control fitting

### Filling hose

### Cylinder pressure regulator

1 Parts lists

#### 2480.00.32.21 Filling and control fitting

A	Pressure gauge	2480.00.32.01.001
B	Valve operating pin	2480.00.32.01.002
C	Screw knob for connection to gas spring (complete)	2480.00.32.01.003
D	Screw knob for connection to gas spring (separate)	2480.00.32.01.003.01
E	Air release valve	2480.00.32.01.005
F	Basic body	2480.00.32.01.006
G	Quick connector, plug	248.00.60.4
H	Ball-Ø 4 mm	206.71.40 G10.P3
R	Usit ring	2480.00.32.10.01

#### 2480.00.31.02 Filling hose

available in 2 lengths:

2480.00.31.02 2 m

2480.00.31.02.005 5 m

I	Shut-off valve	2480.00.32.01.004
J <sup>1)</sup>	Quick connector, socket	248.00.60.3
K <sup>2),3)</sup>	Fill hose	2480.00.32.01.020

1) also for connection to control fittings

2) for connection to 200 bar gas cylinder or cylinder pressure regulator

#### 2480.00.32.07. Cylinder pressure regulator

			200 bar	300 bar
L	Pressure regulator	2480.00.32.07.01	x	x
M <sup>3)</sup>	Gas cylinder connector 200 bar	2480.00.32.07.02	x	
N <sup>4)</sup>	Gas cylinder connector 300 bar	2480.00.32.07.03		x
O <sup>5)</sup>	Connecting adapter	2480.00.32.07.04	x	x
P	Gas cylinder pressure gauge (admission pressure)	2480.00.32.07.01.002	x	x
Q	Filling pressure gauge (back pressure)	2480.00.32.07.01.003	x	x
T	Filling pressure regulator		x	x

3) threads W24,32 × 1/14 nach DIN 477-1

4) thread W30 × 2 nach DIN 477-5

5) for connection to filling hose 2480.00.31.02

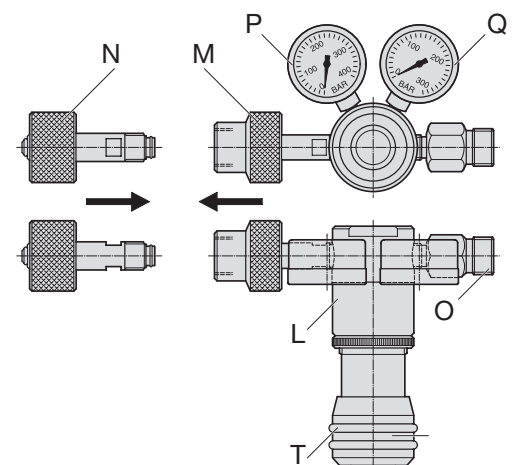
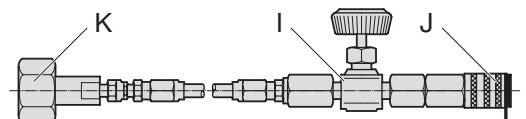
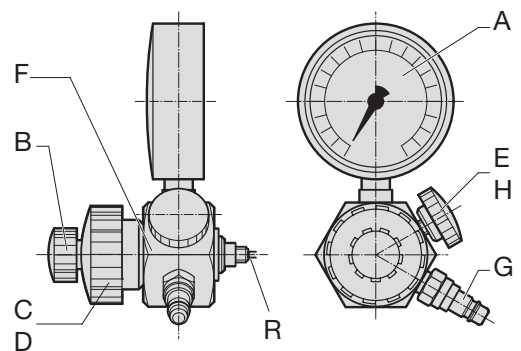

## 2 Description

---

The filling and control fitting 2480.00.32.21 is used for filling, releasing and checking the gas pressure in gas springs. Connection to the gas cylinder is always with the filling hose 2480.00.31.02, either directly (only with 200 bar gas cylinders) or indirectly using the pressure regulator 2480.00.32.07.01, gas cylinder connector 2480.00.32.07.03 (for 300 bar gas cylinders) or gas cylinder connector 2480.00.32.07.02 (for 200 bar gas cylinders) and connection adapter 2480.00.32.07.04.



**For 300 bar gas cylinders it is absolutely essential to use the 2480.00.32.07. gas cylinder regulator.**



**200 bar nitrogen gas cylinders can be connected directly to the gas cylinder connection using the filling hose 2480.00.31.02.**



## 3 Safety Instructions

---

**According to the Pressure Devices Directive 2014/68/EU, the components listed in these operating instructions may only be commissioned, maintained, repaired or overhauled by appropriately instructed and trained personnel, or by FIBRO.**

**Failure to observe the operating instructions can lead to accidents or injuries, for which FIBRO GmbH shall have no liability.**

**FIBRO is not liable if fittings that are not original FIBRO fittings or fastening, accessory, and attachment parts that are not released by FIBRO are used.**

- 3.1 Before starting work on filling and control fitting, the filling hose or the pressure regulator always ensure that there is no pressure in the components.
- 3.2 Keep all components clean and do not oil or grease them.
- 3.3 The gas regulator uses an internal spring. Never dismantle the pressure regulator (L).
- 3.4 The commissioning of the components listed in these instructions is to be carried out only by suitable trained staff or by FIBRO.
- 3.5 Please also observe the safety instructions in the gas spring maintenance manuals.
- 3.6 After the blanking plug has been removed, no person should be directly opposite the valve opening.
- 3.7 Only fill with pure nitrogen N<sub>2</sub>.
- 3.8 Never exceed the maximum filling pressure.
- 3.9 If products listed in these instructions are modified or used inappropriately safety cannot be guaranteed and FIBRO cannot accept any liability whatsoever.
- 3.10 For 300 bar nitrogen cylinders it is absolutely essential to use the 2480.00.32.07. gas cylinder regulator.

Further information may be obtained from the FIBRO gas spring operation and maintenance manuals. You can also contact your local agent or FIBRO GmbH, Standard Parts Division.



# User's Guide

## Filling and control fitting

### Filling hose

### Cylinder pressure regulator

#### 4 Installing and commissioning the gas cylinder pressure regulator

- 4.1 Screw the gas cylinder connector 2480.00.32.07.0x (N or M depending on the type of gas cylinder) on to the left hand side of the gas cylinder pressure regulator. The sealing surfaces must be clean and undamaged and completely free from oil and grease.
- 4.2 Screw the connection adaptor 2480.00.32.07.04 (O) into the opening on the right hand side. The sealing surfaces must be clean and undamaged and completely free from oil and grease.
- 4.3 Screw the connection adaptor (O) on to the filling hose 2480.00.31.02.
- 4.4 Mount the complete unit on the gas cylinder connection.
- 4.5 Open the filling pressure regulator (T) fully counterclockwise, right to the limit.  
 **Failure to do this may damage the pressure regulator.**  
Open the gas cylinder valve slowly, until the gas pressure registers on the gas pressure gauge (P).
- 4.6 Check the system is gas tight.
- 4.7  **If there are leaks, never tighten or slacken the connections without first depressurising the system completely.**  
Set the filling pressure regulator (T) to the required value, displayed on the filling pressure gauge (Q). (Turn clockwise to increase the pressure, counterclockwise to reduce it.)
- 4.8 A slight increase in pressure in the filling hose 2480.00.31.02 when the shut-off valve (I) is closed is normal and it will return to the previous value when the valve is reopened.

#### 5 Filling gas springs

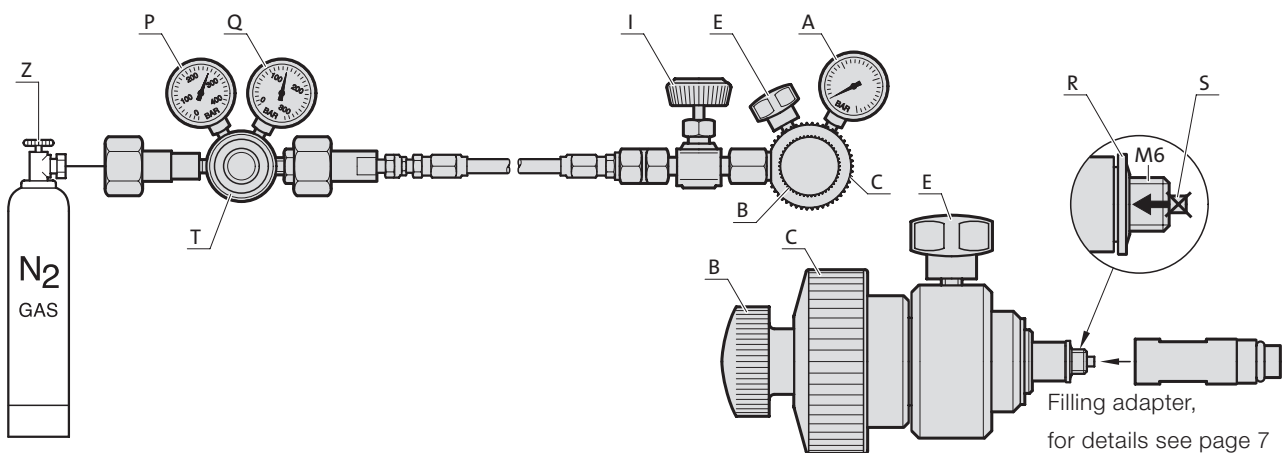

- 5.1 To fill gas springs connect the filling hose 2480.00.31.02 and, if necessary, the gas cylinder pressure regulator 2480.00.32.07. to the nitrogen cylinder.
- 5.2 The discharge valve (E) and the shut-off valve (I) must be closed (turn clockwise). The detent pin (S) must be in the withdrawn position in the M6 thread of the fitting (turn small knob (B) counterclockwise).

- 5.3 Fit the seal (R) on the M6 thread of the fitting then screw the fitting into the filling opening of the gas spring using the screw knob (C). Two filling adapters are enclosed for the various gas spring connections (for details, see page 7).
- 5.4 Start filling by slowly opening the shut-off valve (I). The pressure gauge (A) will show the gas pressure being applied to the gas spring.



**Never exceed the maximum filling pressure of the gas spring. Ensure the gas flow is gradual or the valve of the gas spring may be damaged.**

- 5.5 After filling, release the nitrogen from the fitting by first closing the shut-off valve (I) and then opening the discharge valve (E) until the gas has been fully released.
- 5.6 Completely unscrew the fitting using the large knob (C). Check the valve for leakage. Screw the blanking plug into the filling opening of the gas spring.



**The valve of a filled gas spring is under high pressure so no person should ever be opposite the valve opening.**

## 6 Checking and emptying gas springs

---



**The filling hose and cylinder pressure regulator are not required for testing or releasing the gas pressure in the gas spring.**

- 6.1 The side discharge valve (E) must be closed (turn clockwise).
- 6.2 The detent pin (S) must be in the withdrawn position in the M6 thread of the fitting (turn small knob (B) counterclockwise).
- 6.3 Screw the filling and control fitting with the filling adapter into the gas spring using the screw knob (C).
- 6.4 With care gradually turn small valve knob (B) of the gas spring clockwise until the pressure gauge registers a reading.



**Turning the knob too fast or too far will destroy the valve.**

- 6.5 The filling pressure is displayed on the pressure gauge (A).
- 6.6 To empty the gas from the gas spring, slowly open the discharge valve (E).
- 6.7 If you are just checking the gas pressure, turn the small knob (B) fully counter-clockwise and then open the discharge valve (E).



**Every time you check the pressure, there will inevitably be a small loss of nitrogen from the gas spring.**

- 6.8. Unscrew the filling and control fitting from the gas spring.
- 6.9 Screw the blanking plug back into the filling opening of the gas spring.

# User's Guide

## Filling and control fitting

### Filling hose

### Cylinder pressure regulator

7 Technical data

---

#### 7.1 Filling and control fitting 2480.00.32.21\*

Max. operating pressure	207 bar
Display range	0 – 250 bar
Display accuracy	± 5%
Operating temperature range	0 °C – 50 °C
Approved gas	Nitrogen N <sub>2</sub>
Weight	0,6 kg

#### 7.2 Filling hose 2480.00.31.02\*

Max. operating pressure	207 bar
Operating temperature range	0 °C – 50 °C
Approved gas	Nitrogen N <sub>2</sub>

#### 7.3 Cylinder pressure regulator 2480.00.32.07.\*

Max. operating pressure	300 bar
Display accuracy	± 2,5%
Inlet connector ø 16x1.336SI	300 bar
Outlet connector G <sup>3</sup> / <sub>8</sub>	200 bar
Rated pressure (max. pressure reduction)	20 – 200 bar
Rated flow	30 m <sup>3</sup> /h at 23 °C; 1,013 bar
Operating temperature range	-20 °C to +50 °C
Approved gas	Nitrogen N <sub>2</sub>
Weight	~ 1,8 kg

\*We reserve the right to make technical modifications

**Filling adapter 2480.00.32.10<sup>1)</sup>**

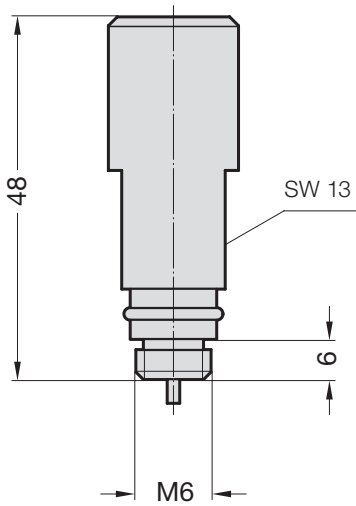

**Filling adapter 2480.00.32.11<sup>1)</sup>**

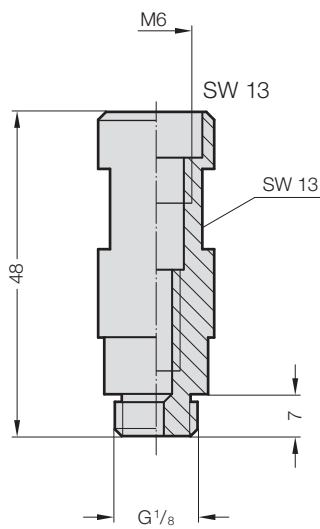

<sup>1)</sup> included in the filling and control fitting 2480.00.32.21

		Spring type		Filling adapter 2480.00.32		
				without	.10	.11
<b>2479.</b>	030.					
	031.					
	034.					
	040.					
	041.					
<b>2480.</b>	12.	10000.			x	
	13.	00250.	x			
	13.	00500. - 07500.			x	
	15.	00150. - 00250.	x			
		00500. - 10000.			x	
	21.		x			
	22.		x			
	24.		x			
	25.		x			
	32.		x			
	33.		x			
	35.		x			
82.		x				
<b>2482.</b>	72.		x			
	73.		x			
	74.		x			
	75.		x			
	76.		x			
	77.		x			
<b>2484.</b>	12.				x	
	13.				x	
<b>2485.</b>	12.				x	
	15.				x	
<b>2486.</b>	12.				x	
	22.				x	
<b>2487.</b>	12.	00170. - 02400. 04200. - 20000.	x		x	
	15.	00170. - 02400. 04200. - 20000.	x		x	
	12.33.				x	
	15.33.				x	
	82.		x			
<b>2488.</b>	13.				x	
	15.				x	
<b>2490.</b>	14.	00420. - 00750. 01000.	x	x		
		01800. - 18300.			x	
	15.	00420. - 07500. 11800. - 18300.	x		x	
<b>2496.</b>	12.		x			
<b>2497.</b>	12.	00500. - 01900.	x			
	15.	00320. - 01000.	x			
		01900. - 12800.			x	

**[www.fibro.com](http://www.fibro.com)**

FIBRO GmbH  
Business Unit Normalien  
August-Läpple-Weg  
74855 Hassmersheim  
GERMANY  
T +49 6266 73-0  
[info@fibro.de](mailto:info@fibro.de)

02/2026 Order No. 2.7517.02.0425.0100000