

# **OPERATION AND MAINTENANCE MANUAL**

## **MANIFOLD SYSTEM**

2495.XXXXXXX.

## **MANIFOLD CYLINDERS**

2495.13.

2495.23.

2495.33.

## **MANIFOLD ACCESSORIES**

2495.00.

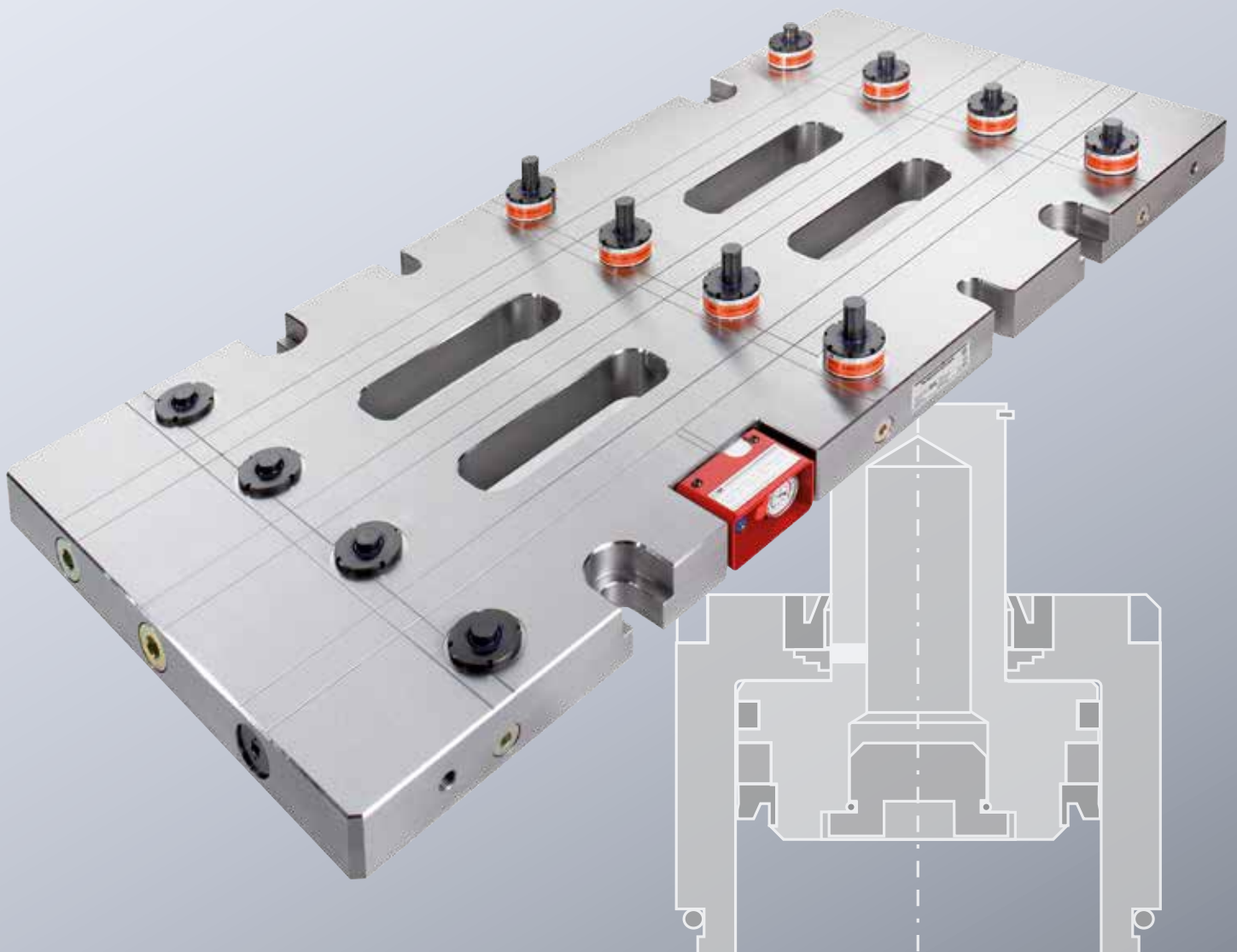

# OPERATION AND MAINTENANCE MANUAL

## MANIFOLD SYSTEM

### 1 PARTS LIST

#### 1.1 Manifold cylinder 2495.13./23./33.

- A<sup>1),2)</sup> Circlip
- B Piston
- C<sup>1)</sup> Stripper ring
- D Casing
- E<sup>1),2)</sup> Guide ring
- F<sup>1)</sup> Lubrication ring
- G<sup>1)</sup> Support and guide ring
- H<sup>1)</sup> Seal
- I O-ring for blanking plug
- J Blanking plug
- K<sup>1)</sup> Viton O-ring

- <sup>1)</sup> Included in the spares pack and must be replaced completely.
- <sup>2)</sup> Not required for manifold cylinder Type 2495.33. in flat design.

Spare parts kit for cylinder type:

2495.13./23./33.02500.XXX = 2495.13.02500

2495.13./23./33.05500.XXX = 2495.13.05500

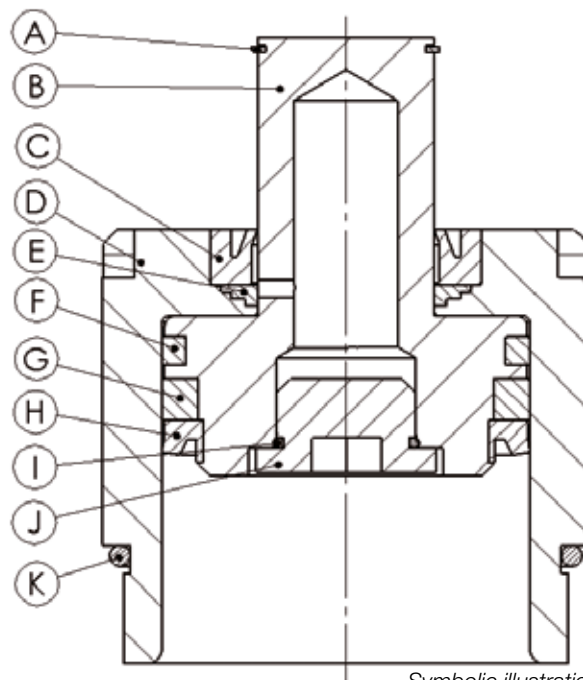

Symbolic illustration

#### 1.2 Filling and control fitting 2495.00.31.0X; 2495.00.31.02.DC

- L Frame
- M Body
- N Screw M10x30 (2x)
- O Bleeder valve (2480.00.31.0004)
- P Quick release coupling for compressed air supply (248.00.60.4)
- Quick release coupling for compressed air supply for control fitting 2495.00.31.02.DC (2495.00.31.02.DC.001)
- Q Pressure gauge 0 – 200 bar (0 – 3000 psi)
- R Rupture protection device (2495.00.10.10.02.716)
- S Viton O-ring (back)

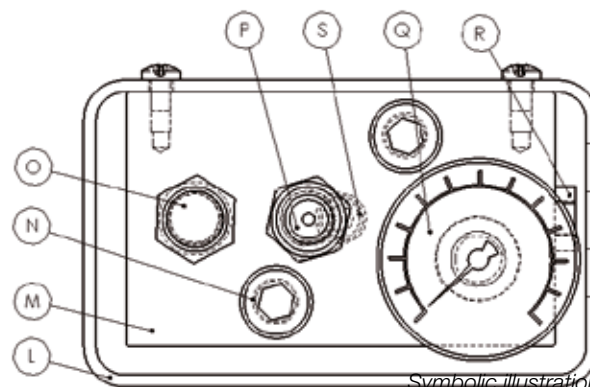

Symbolic illustration

## 2 TOOLS REQUIRED

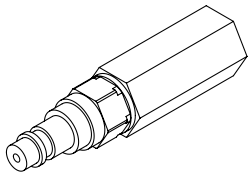

Filling adapter for Control  
fitting 2495.00.31.02.DC  
(2495.00.31.02.21)



Special key  
2495.00.51.XXXXX

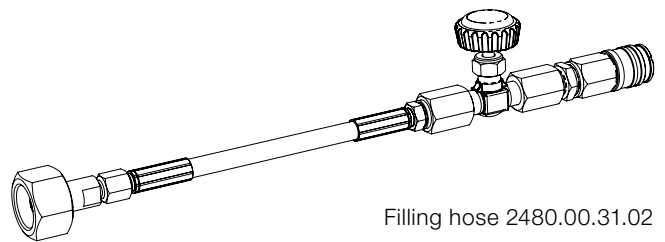

Filling hose 2480.00.31.02

## 3 SAFETY INSTRUCTIONS



**In accordance with the pressure directive (PED) 2014/68/EU the maintenance, servicing, repair and overhaul of the components listed in these instructions is to be carried out only by suitable trained staff or by FIBRO.**

**Failure to comply with these instructions may cause accidents or injuries, for which FIBRO cannot in any way be held responsible.**

**FIBRO is not liable if fittings that are not original FIBRO fittings or fastening, accessory, and attachment parts that are not released by FIBRO are used.**

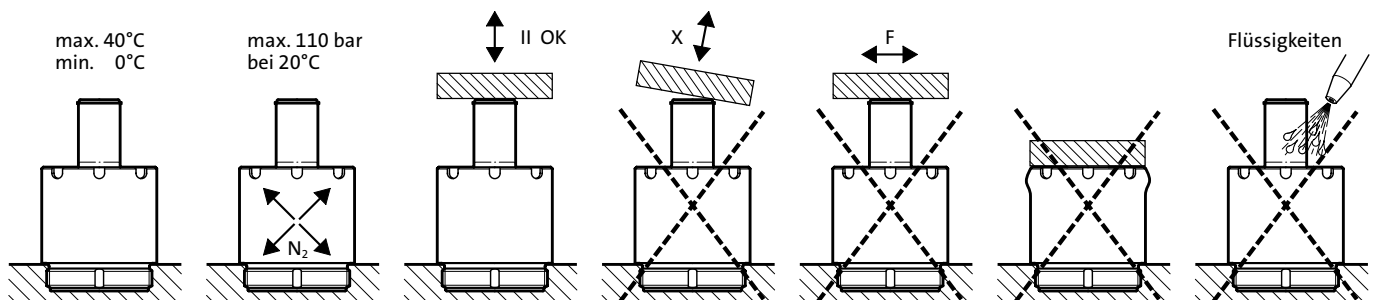

- 3.1 Only use genuine FIBRO spare parts.
- 3.2 Risk of serious injury: Always release the nitrogen gas pressure completely before attempting repairs or maintenance. Because of the large volume of gas contained in the manifold system it may take several minutes for the nitrogen to be released fully. Never start work when there is still residual pressure in the system. Pressure has only been equalised when you can push in the piston rod of the manifold system gently with a rubber hammer.
- 3.3 Never attempt mechanical work (boring, milling) on the manifold without first contacting specialists at FIBRO to discuss.
- 3.4 Never exceed max. operating temperature of 40 °C.
- 3.5 Never exceed the maximum permitted filling pressure of 110 bar at 20 °C.
- 3.6 Never allow the manifold cylinders to be released suddenly from compressed position.
- 3.7 Never allow the maximum rated travel to be exceeded or components may burst, resulting in injury.
- 3.8 The manifold system must only be filled with nitrogen N<sub>2</sub>.  
In high concentrations nitrogen causes suffocation. Never inhale nitrogen and only use in well ventilated spaces.

# OPERATION AND MAINTENANCE MANUAL

## MANIFOLD SYSTEM

- 3.9 Never subject the manifold system to any form of heat treatment (welding, hardening etc.) without first discussing with specialists at FIBRO.
- 3.10 Never replace the rupture protection in the filling fitting and/or replace it with a normal blanking plug in the manifold. (Caution: special thread).
- 3.11 Always respect the stated torque values for the blanking plugs and manifold cylinders (see table 1 on page 6).
- 3.12 Fitting and removing manifold cylinders may require a high degree of force and must only be undertaken with authorised tools fit for the purpose. Consequently the manifold must be sufficiently firmly mounted to ensure it cannot slip.
- 3.13 When parts are replaced, they must be replaced only with genuine new and original spare parts. Please contact your FIBRO advisor.
- 3.14 Increasing the travel at a later date by adding a manifold cylinder with greater travel may not be permitted and may result in the invalidation of the PED 2014/68/EU approval. If you need to increase the travel, please contact your FIBRO advisor.
- 3.15 The manifold system should only be transported using lifting devices screwed into the threaded bores provided for this purpose. Using the threaded bores in the manifold cylinder or the blanking plate thread for mechanical handling purposes is not permissible.
- 3.16 Filling with nitrogen must be a gradual process to avoid the manifold piston shooting out suddenly.
- 3.17 To operate the manifold, it must be ensured that there is sufficient special oil 248.00.50 in the pressure chamber. The necessary amount of oil is mentioned on the nameplate.

#### 4 RUPTURE PROTECTION AND CONTROL FITTING

---

A manifold system always consists of the following units as a minimum:

- a) Plate 2495.
- b) Manifold cylinder 2495.13./23./33.
- c) Blanking plug 2495.00.10.
- d) Filling and control fitting 2495.00.31.
- e) Rupture protection 2495.00.10.10.02.78

The filling and control fittings are either bolted direct to the manifold or connected to the manifold via a measuring hose (We recommend: Mini measuring hose 2480.00.23.0x) connected to the manifold.

The required rupture protection device 2495.00.10.10.02.78 is screwed directly into the manifold and has a special thread to prevent blanking plugs being used.

Rupture protection devices are triggered at about 146 bar system pressure and release the gas in a controlled way into the environment. Before the system can be refilled, the rupture protection device has to be replaced with an identical new one.

#### 5 REMOVING THE MANIFOLD SYSTEM

---



**The manifold system must always be mounted on a suitable base.**

##### 5.1 Removing the Manifold Cylinder 2495.13./23./33.



**Before removing individual components it is essential that the pressure is released fully from the system (see also Safety Instructions 3.2).**

**Turn the bleed valve (O) on the filling and control valve 2495.00.31. counterclockwise and release the gas pressure.**

- 5.1.1 Gently press in the piston rod of the manifold cylinder using a rubber hammer.
- 5.1.2 Turn the manifold cylinder 2495.13./23./33. counterclockwise using the special key. Undo 2495.00.51.

## 5.2 Undoing the blanking plug 2495.00.10.01.



**Before removing individual components it is essential that pressure is released fully from the system (see also Safety Instructions 3.2).**

**Turn the bleed valve (O) on the filling and control fitting 2495.00.31. counterclockwise and release the gas pressure.**

5.2.1 Release the side blanking plugs 2495.00.10. on the manifold cylinder using a hexagonal wrench.

## 5.3 Dismantling the filling and control fitting 2495.00.31.



**Before removing individual components it is essential that pressure is released fully from the system (see also Safety Instructions 3.2).**

**Turn the bleed valve (O) on the filling and control fitting 2495.00.31. counterclockwise and release the gas pressure.**

5.3.1 Undo both the M10 Allen screws by turning counterclockwise.

5.3.2 Remove the Viton O-ring which is between the manifold and the back of the filling and control fitting.

## 6 MAINTENANCE ON MANIFOLD CYLINDER 2495.13./ 23./ 33.

6.1 Dismantling, see 5.1

6.2 Remove the circlip (A, see picture page 2) at 2495.13./23.

6.3 Press the piston (B) gently downwards until it can be removed from the casing (D).

6.4 Using a small screwdriver, lever out the stripping ring (C), guide ring (E), lubrication ring (F), support and guide ring (G) and seal (H) (Please note: parts so removed cannot be reused).

6.5 Remove Viton O-ring (K).

6.6 Clean piston and casing.

6.7 Check inside of casing (D) for damage.

6.8 Open spare parts pack and remove individual parts.

6.9 Apply generous lubrication to all the parts.

6.10 Carefully insert the guide ring (E) and the stripping ring (C) using a rubber hammer (make sure it is in the right position, see fig. 1).

6.11 Insert the lubrication ring (F) in the groove.

6.12 Insert the support ring (G).

6.13 Insert seal (H). (check correctly positioned - see fig. 1)

6.14 Insert Viton O-ring (K).

6.15 Insert piston into the casing and press in gently.

6.16 Insert the circlip (A) in the correct groove again.

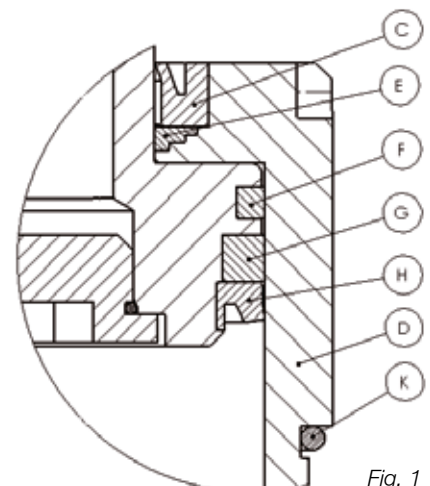

Fig. 1

# OPERATION AND MAINTENANCE MANUAL

## MANIFOLD SYSTEM

### 7 FITTING THE MANIFOLD SYSTEM



Before fitting the manifold always check the open holes for damage to the sealing surfaces or to the thread and for any foreign objects which might have fallen in the plate.

The torque values for fitting the manifold cylinder and the blanking plugs stated in Table 1 in these instructions must be adhered to.

#### 7.1 Fitting the manifold cylinder 2495.13./23./33.

- 7.1.1 Generously lubricate the Viton O-ring (K) of the manifold cylinder.
- 7.1.2 Gently screw in the manifold cylinder into the manifold, clockwise and by hand.
- 7.1.3 Press in the pistons of the manifold cylinder by hand until they are about 5 mm before the end position.
- 7.1.4 Insert the appropriate sized Allen key 2495.00.51. on the manifold cylinder so that the key locate perfectly in the grooves and then tighten with a torque wrench.

#### 7.2 Fitting blanking plug 2495.00.10.

- 7.2.1 Lubricate the Viton O-ring of the blanking plug generously.
- 7.2.2 Tighten the blanking plugs with a torque wrench.

#### 7.3 Fitting the control fitting 2495.00.31.

- 7.3.1 Montage 2495.00.31.01/02/02.DC (direct attachment)
  - 7.3.1.1 Insert the O-ring (S) for the filling and control fitting 2495.00.31.01/02/02.DC in its groove in the manifold.
  - 7.3.1.2 Then screw the filling and control fitting on to the manifold using the two socket head cap screws (N).



**Ensure that the O-ring does not drop out of its groove.**

- 7.3.2 Fitting 2495.00.31.03 (indirect attachment)
  - 7.3.2.1 Screw the gauging coupling into the correct threaded hole in the manifold.
  - 7.3.2.2 Screw the connecting hose on to the gauging coupling.
  - 7.3.2.3 Connect the other end of the hose with the gauging coupling, which is screwed into the filling and control fitting 2495.00.31.03.

Thread size	Torque	
	Nm	ft-lbs
M14x1,5	45	33
M22x1,5	80	59
M27x2	170	125
M33x2	310	229
M42x2	330	243
M48x2	420	310
M63x2	430-460	315-340
M64x2	430-460	315-340
M82x2	1100	810
M100x2	1100	810

Table 1 Torque values for manifold screws

**i** For filling the manifold system we recommend the use of the pressure regulator 2480.00.32.07. since the required filling pressure can be set and there is then no risk of overfilling the system.

- 8.1 The shut-off valve (T) on the filling hose 2480.00.31.02 and the bleed valve (O) of the filling and control fitting must be closed (turn clockwise to close).
- 8.2 Attach the filling hose connector to the quick release coupling (P) of the filling and control fitting. When using the filling and control fitting 2495.00.31.02.DC, at first screw on the filling adapter (Pos. R) 2495.00.31.02.21.
- 8.3 Open the nitrogen cylinder using the knob (Z). Set the required pressure at the filling pressure regulator (V). The gas cylinder pressure gauge (Y) displays the cylinder pressure; the filling pressure gauge (X) displays the filling pressure.
- 8.4 Slowly open the shut-off valve (T) on the fitting and start filling. The pressure gauge (Q) will show the gas pressure being applied to the manifold system.

**⚠** **Maximum filling pressure 110 bar. It is essential to let the gas fill slowly for two reasons: firstly to avoid damage to the filling and control fitting and secondly to avoid the piston suddenly shooting out of the manifold cylinder.**

- 8.5 After completion of the filling operation close the shut-off valve (T) and release the filling hose from the quick release coupling (P).
- 8.6 When using the filling and control fitting 2495.00.31.02.DC, remove the filling adapter (Pos. R).
- 8.7 Close the nitrogen cylinder using the knob (Z). Then open the shut-off valve (T) on the filling hose to empty the system completely.

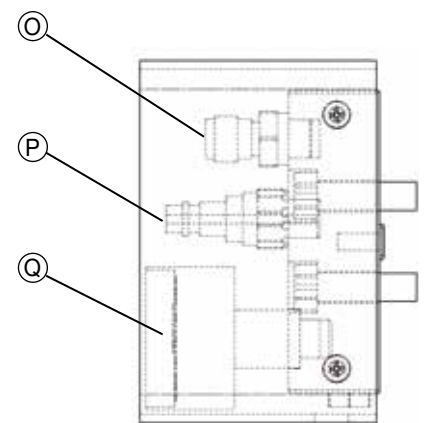
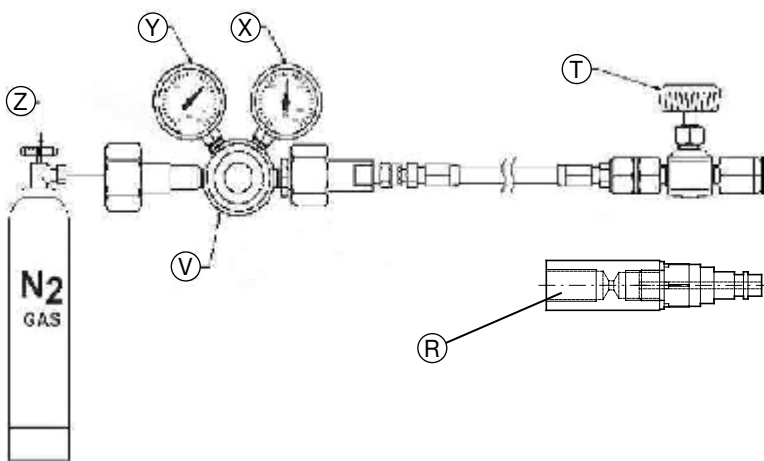

*Symbolic illustration*

**FIBRO GMBH**

Business Area Standard Parts  
 August-Läpple-Weg  
 74855 Hassmersheim  
 GERMANY  
 T +49 6266 73-0  
 info@fibro.de

**THE LÄPPLE GROUP**

Läpple Automotive  
 Fibro  
 Fibro Läpple Technology  
 Läpple Aus- und Weiterbildung

**LOCATIONS****FIBRO France Sarl**

Département Eléments normalisées  
 26 Avenue de l'Europe  
 67300 Schiltigheim  
 FRANCE  
 T +33 390 204040  
 info@fibro.fr

**FIBRO Inc.**

Business Area Standard Parts  
 139 Harrison Avenue  
 Rockford, IL 61104  
 USA  
 T +1 815 2291300  
 info@fibroinc.com

**FIBRO Sp. z o.o.**

Aleja Armii Krajowej 220  
 Pawilon AG piętro 3/ pokój 306  
 43-316 Bielsko-Biała  
 POLSKA  
 T +(48) 6980 57720

**FIBRO INDIA****PRECISION PRODUCTS PVT. LTD.**

Business Area Standard Parts  
 Plot No: A-55, Phase II, Chakan Midc,  
 Taluka Khed, Pune – 410 501  
 INDIA  
 T +91 2135 33 88 00  
 info@fibro-india.com

**FIBRO (Shanghai)****Precision Products Co., LTD.**

Business Area Standard Parts  
 1st Floor, Building 3  
 No. 253, Ai Du Road  
 Pilot Free Trade Zone  
 Shanghai 200131  
 CHINA  
 T +86 21 60 83 15 96  
 info@fibro.cn

**FIBRO Asia Pte. Ltd.**

Business Area Standard Parts  
 9 Changi South Street 3, #07-04  
 Singapore 486361  
 SINGAPORE  
 T +65 65 439963  
 info@fibro-asia.com

**FIBRO KOREA Co., LTD.**

203-603, Bucheon Technopark  
 Ssangyong 3  
 397, Seokcheon-ro, Ojeong-gu,  
 Bucheon-si, Gyeonggi-do  
 KOREA  
 T +82 032 624 0630  
 fibro\_korea@fibro.kr