



Montageanleitung
Vierkantbundflansch,
verdrehgesichert

Mounting Instructions
Square Collar Flange,
anti-twist

Instructions de montage
Bride à carré d'entraînement,
avec blocage en rotation

2480.064.

 **FIBRO**

Montageanleitung Vierkantbundflansch, verdrehgesichert

1 Stückliste

Obere Flanschkälfte (1x)

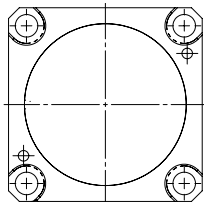

Befestigungsschraube (4x)
(nicht im Lieferumfang)

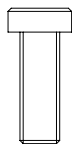

Vor-Montageschraube (4x)

Halteringhälfte (2x)

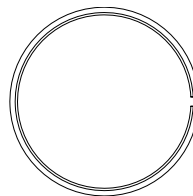

Klemmring (1x)

Untere Flanschkälfte (1x)

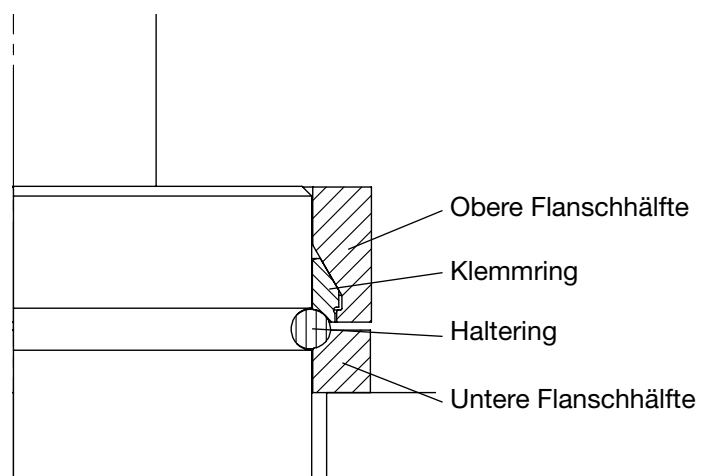
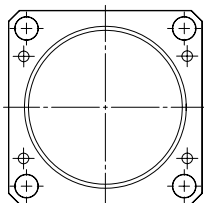

2 Montage/Demontage

Vor dem Zusammenbau ist folgendes zu beachten!



- 1.) Klemmring korrekt in untere Flanschkälfte montieren (siehe Abb.)
- 2.) Vor-Montageschrauben nicht anziehen, bevor die Gasdruckfeder montiert ist
- 3.) Anzugmoment der Befestigungsschrauben nach unten stehender Tabelle auswählen

Montage

- 1.) Halteringe in C-Nut der Gasdruckfeder einlegen
- 2.) Gasdruckfeder lose in untere Flanschkälfte einhängen
- 3.) Obere Flanschkälfte montieren (Vor-Montageschrauben nur anlegen)
- 4.) Befestigungsschrauben kreuzweise in min. 5 Schrittfolgen anziehen (Anziehen der Befestigungsschrauben in 1/5-Schritten des Gesamtanzugmoments)
- 5.) Vor-Montageschrauben anziehen



Demontage

Beachte! Vor-Montageschrauben vor den Befestigungsschrauben lösen.

Zylinderschrauben mit Innensechskant und niedrigem Kopf (empfohlen)

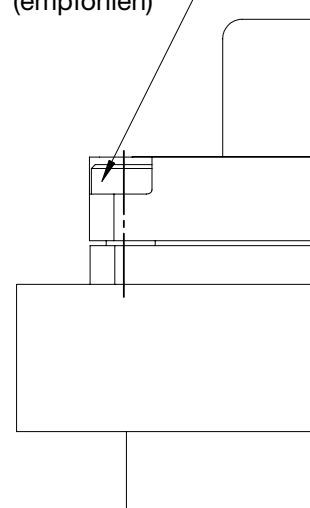

Artikelnummer	Befestigungsschraubengröße	Befestigungsschrauben Anzugsmoment [Nm]
2480.064.00500	M8	25
2480.064.00750	M8	25
2480.064.01000	M10	50
2480.064.01500	M10	50
2480.064.03000	M12	90
2480.064.05000	M12	90
2480.064.07500	M16	160

Mounting Instructions

Square collar flange, anti-twist

1 Parts List

Top flange half (1x)

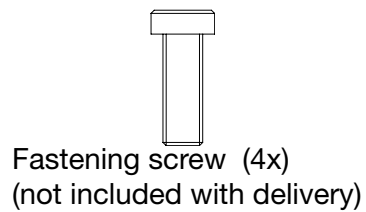
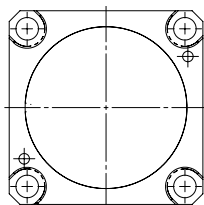

Fastening screw (4x)
(not included with delivery)

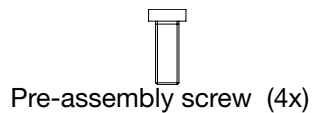

Pre-assembly screw (4x)



Retaining ring half (2x)

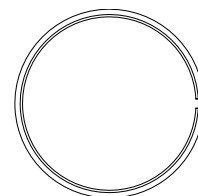

Clamping ring (1x)

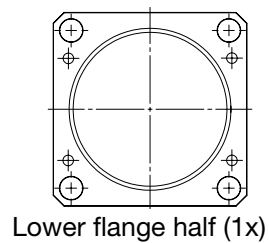

Lower flange half (1x)

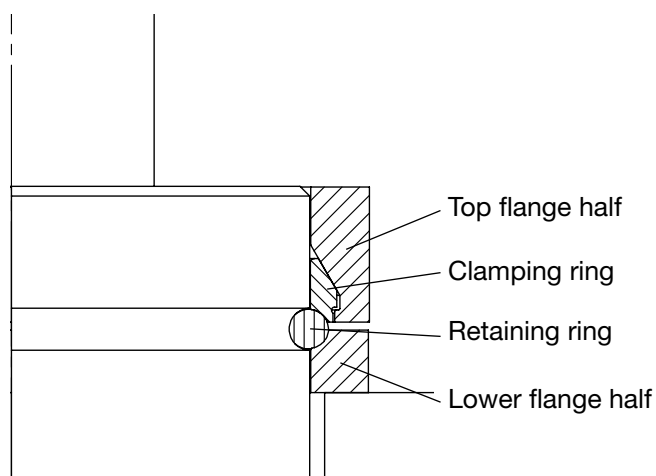

2 Assembly/Disassembly

Before assembly, please note!



- 1.) Install the clamping ring correctly into the lower flange half (see fig.)
- 2.) Do not tighten the pre-assembly screws before the gas spring is installed
- 3.) Select the tightening torque of the fastening screws from the table below

Assembly

- 1.) Insert the retaining rings into the C groove of the gas spring
- 2.) Hook the gas spring loosely into the lower flange half
- 3.) Install the top flange half (set the pre-assembly screws in place only)
- 4.) Tighten the fastening screws crosswise, tightening a little at a time and moving back and forth around a circle at least 5 times (Tighten the fastening screws in 1/5 increments of the total tightening torque)
- 5.) Tighten the pre-assembly screws



Disassembly

Please note! Loosen the pre-assembly screws before the fastening screws.

Socket head screws with internal hex and low head (recommended)

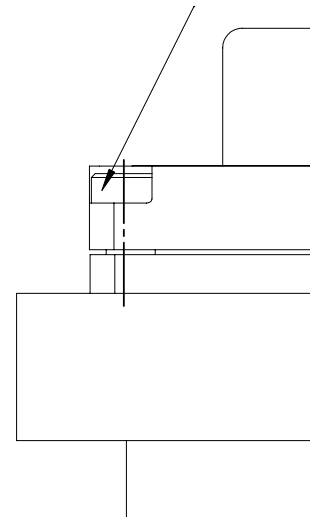

Article number	Size of the fastening screws	Tightening torque of the fastening screws [Nm]
2480.064.00500	M8	25
2480.064.00750	M8	25
2480.064.01000	M10	50
2480.064.01500	M10	50
2480.064.03000	M12	90
2480.064.05000	M12	90
2480.064.07500	M16	160

Instructions de montage

Bride à carré d'entraînement avec blocage en rotation

1 Liste des pièces

Partie supérieure de bride (1x)

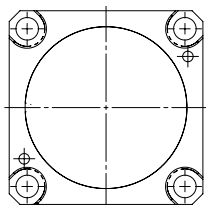

Vis de fixation (4x)
(non inclus dans la livraison)

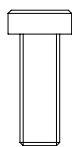

Vis de prémontage (4x)

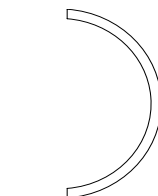

Demi-jonc (2x)

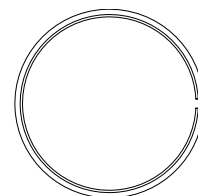

Bague de serrage (1x)

Partie inférieure de bride (1x)

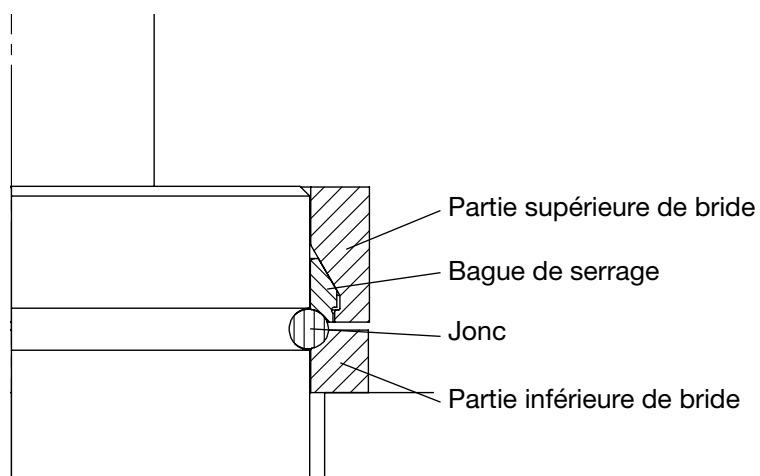
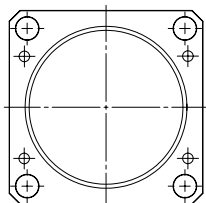

2 Montage/Démontage

Avant le montage, veuillez respecter les instructions suivantes !



- 1.) Monter la bague de serrage correctement dans la partie inférieure de la bride (voir fig.)
- 2.) Ne pas serrer les vis de prémontage avant que le ressort à gaz soit monté
- 3.) Choisir le couple de serrage des vis de fixation selon le tableau ci-dessous

Montage

- 1.) Insérer les joncs dans la rainure en C du ressort à gaz
- 2.) Accrocher le ressort à gaz sur la partie inférieure de la bride sans autre fixation
- 3.) Monter la partie supérieure de la bride (poser les vis de prémontage sans les serrer)
- 4.) Serrer les vis de fixation en croix en 5 étapes minimum (Serrer les vis de fixation en mesures de 1/5 du couple de serrage total)
- 5.) Serrer les vis de prémontage

Démontage



Attention ! Desserrer les vis de prémontage avant les vis de fixation.

Vis à tête cylindrique
à six pans creux et à tête
basse (recommandé)

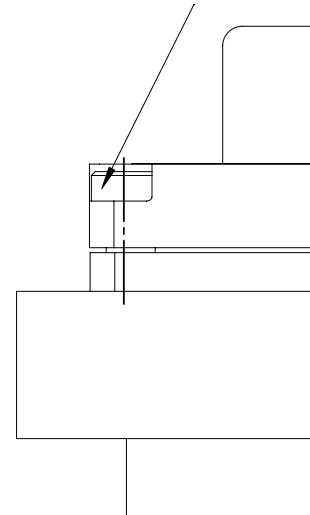

Référence	Taille des vis de fixation	Couple de serrage des vis de fixation [Nm]
2480.064.00500	M8	25
2480.064.00750	M8	25
2480.064.01000	M10	50
2480.064.01500	M10	50
2480.064.03000	M12	90
2480.064.05000	M12	90
2480.064.07500	M16	160

Normalien
Standard Parts
Éléments normalisés

FIBRO GmbH **DE**
August-Läpple-Weg
74855 Hassmersheim
T +49 6266 73-0
F +49 6266 73 237
info@fibro.de

FIBRO France Sarl **FR**
26, avenue de l'Europe
67300 Schiltigheim
T +33 3 90 20 40 40
F +33 3 88 81 08 29
info@fibro.fr

FIBRO Inc. **US**
139 Harrison Avenue
Rockford, IL 61104
T +1 815 2 29 13 00
F +1 815 2 29 13 03
info@fibroinc.com

FIBRO Asia Pte. Ltd. **SG**
9, Changi South Street 3, #07-04
Singapore 486361
T +65 65 43 99 63
F +65 65 43 99 62
info@fibro-asia.com

FIBRO INDIA **IN**
PRECISION PRODUCTS PVT. LTD.
Plot No: A-55, Phase II, Chakan Midc,
Taluka Khed, Pune - 410 501
T +91 21 35 33 88 00
F +91 21 35 33 88 88
info@fibro-india.com

FIBRO (SHANGHAI) **CN**
STANDARD PARTS CO., LTD.
2nd Floor, Building No. 30
No. 188 Hedan Road
Free Trade Zone, Shanghai 200131
T +86 21 60 83 15 89
F +86 21 60 83 15 99
info@fibro-china.com

FIBRO KOREA CO. LTD. **KR**
Namdongsanggong Bd. 401ho
632-1, Gojan-Dong, Namdong-Gu
Incheon, 405-817
T +82 32 821 0130 ~1
F +82 32 821 0030
fibro@chol.com