

USER'S GUIDE **FLEX CAM SYSTEM**

HYDRAULIC CYLINDERS AND TOOL SLIDES FOR TOOL AND MOULD MAKING AND MECHANICAL ENGINEERING

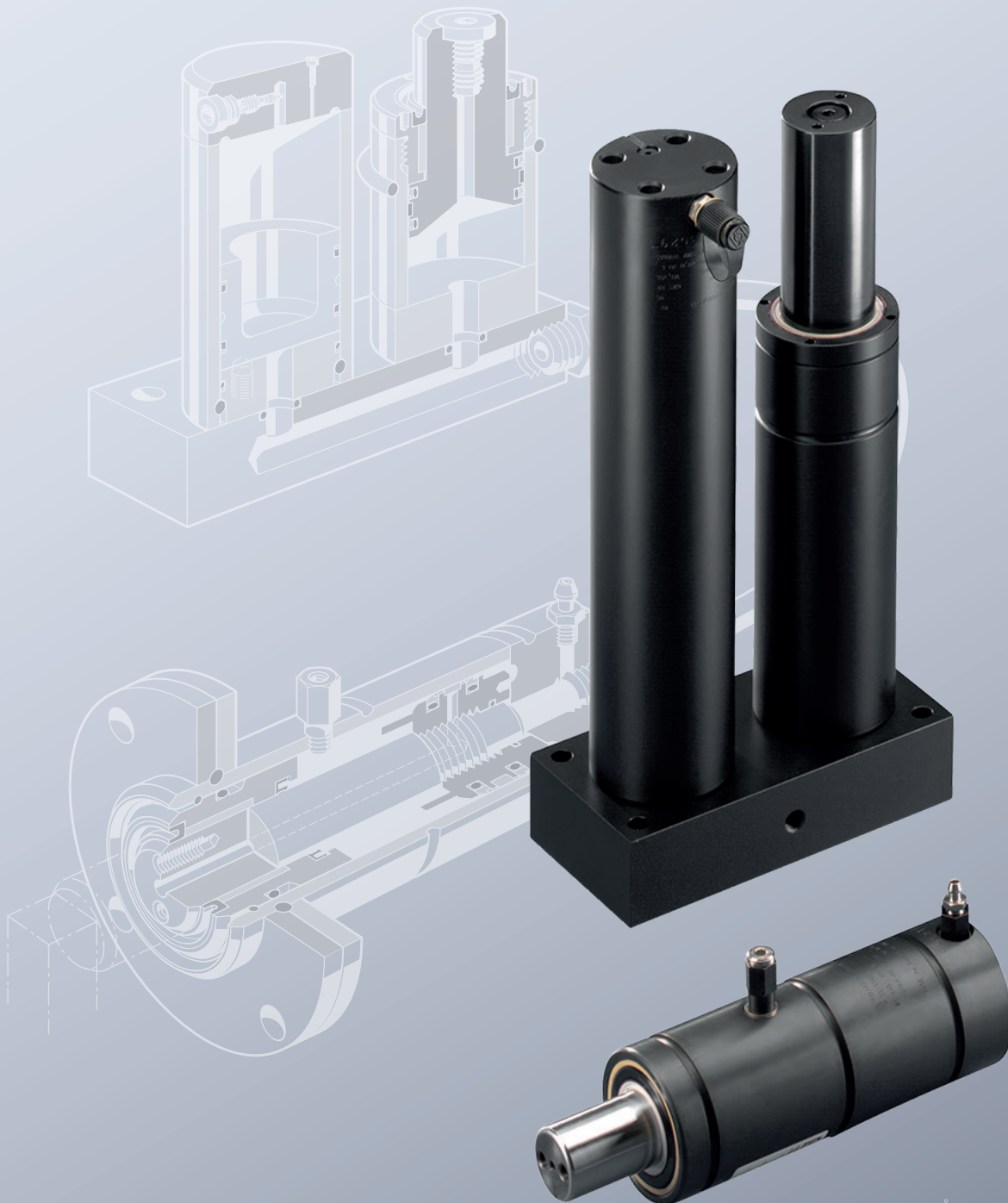

USER'S GUIDE FLEX CAM SYSTEM

THESE OPERATING INSTRUCTIONS ARE APPLICABLE TO:

Hydraulic cylinders and tool slides (Flex cam system),
type 2018.10., 11., 20., 30., 40., 50. and 60.xxxxx.xxx

USER'S GUIDE FLEX CAM SYSTEM

PART A TECHNICAL DESCRIPTION

SECTION

1	GENERAL SAFETY INSTRUCTIONS	PAGE 4
2	INTRODUCTION	PAGE 7
3	DESCRIPTION OF THE COMPONENTS	PAGE 8
4	DESCRIPTION OF THE FUNCTIONS	PAGE 11
5	DIMENSIONS	PAGE 14
6	TECHNICAL DATA	PAGE 14

PART B ASSEMBLY AND MAINTENANCE

SECTION

7	SAFETY INSTRUCTIONS	PAGE 16
8	ASSEMBLY	PAGE 18
9	FILLING WITH NITROGEN GAS AND OIL	PAGE 21
10	MAINTENANCE AND SERVICING	PAGE 24

USER'S GUIDE

FLEX CAM SYSTEM

1. GENERAL SAFETY INSTRUCTIONS

This state-of-the-art device is constructed in accordance with the applicable regulations. Particular emphasis was placed on user safety.

The following regulations apply:

- the applicable accident prevention regulations
- generally accepted safety rules
- EU Directives
- country-specific requirements

Significance of the Operating Instructions

The operating instructions are part of the device and should therefore:

- be kept to hand at all times, i.e. until the device is disposed of
- be passed on to the new user if the device is sold, loaned or otherwise disposed of

Always contact the manufacturer if any of the information in these operating instructions is unclear.

Even if these rules are followed, the device still presents an unavoidable risk of injury or damage. Anyone who carries out transportation, erection, operation, maintenance or repair on this device must therefore be trained and made aware of the possible risks. They must carefully read, understand and follow these operating instructions, particularly the safety instructions.

FIBRO GmbH shall not be held liable for any loss or damage resulting from lack or insufficient knowledge of These operating instructions. We therefore recommend that the operator ensure that every person involved confirms in writing that they have received the necessary instruction.

The operator's responsibilities

According to the EU Use of Equipment Directive 89/655/EEC Art. 6(1) and 7 and the EU Principle Directive 89/391/EEC Art. 1(1) and 6(1), the operator is required to provide instruction, particularly concerning the safety aspects, to all personnel who are involved in the assembly, operation, maintenance, repair or disassembly of a device.

According to the EU Use of Equipment Directive 89/655/EEC Art. 4a, the operator is also responsible for inspecting the device before commissioning, after repairs and after malfunctions.

Correct usage

This device may only be used to actuate tool slides, mould wedges, clamping pads, punches and interlocks.

Use of the device for any other tasks must first be discussed with and approved by the manufacturer.

Incorrect usage

- The device may not be used
- in potentially explosive atmospheres
 - in the open air

The manufacturer must be contacted before the device is operated in ambient conditions other than those specified under "Technical data".

Who may operate the device?

Only trained and appropriately authorised personnel may operate the device.

Assembly, retrofitting, maintenance and servicing require special knowledge and may only be carried out by appropriately trained, specialist personnel.

Conversion and modification of the device

This device may only be retrofitted using options and accessories from FIBRO GmbH.

For safety reasons, the device and its functions may not be converted or modified. FIBRO GmbH shall not be held liable for any conversions to the device not expressly approved by the manufacturer. The "Maintenance and repair" section should be followed during any maintenance or repair work.

Original parts and accessories are specially designed for this device. Parts and equipment made by other manufacturers have not been tested by us, so their use is not approved. The safety and correct operation of the device may be affected if such parts and equipment are attached or installed. FIBRO GmbH shall not be held liable for any damage caused by the use of non-original parts and equipment.

USER'S GUIDE

FLEX CAM SYSTEM

Faults

- Always report faults or other damage immediately to the responsible person. Secure the device to prevent incorrect or accidental use. Repairs must only be carried out by trained specialist personnel
- Never bypass or disable protective and safety devices
- Dismantled safety devices must be
 - reinstalled in the machine before it is restarted, and
 - checked to ensure that they are functioning correctly

Information plates and adhesive labels

Labels, information plates and adhesive labels must be fully legible at all times and the instructions they contain must be followed. Replace any information plates or adhesive labels that are damaged or illegible.

USER'S GUIDE FLEX CAM SYSTEM

SAFETY INSTRUCTIONS



This symbol indicates possible risks to personnel or to the system. Always follow the instructions which are intended to prevent injury or damage to the system.



This symbol indicates special information intended to improve or facilitate use of the device.

FOR YOUR OWN SAFETY

Supplementary instructions

If this device was equipped with FIBRO GmbH accessories, the associated operating instructions should be kept with these operating instructions and carefully followed.

USER'S GUIDE FLEX CAM SYSTEM

2. INTRODUCTION

The flex cam system may be used for drilling, cutting, embossing, drawing and bending operations.

The system enables forces to be distributed flexibly, ensuring that the operation can be performed in the Optimum direction and at the optimum speed.

The system can be used to operate several slaves simultaneously, which means that several operations can be performed on each tool. Use of the hydraulic cam system often means that fewer tools are required for production

The system consists of a hydraulic driving unit, the working unit and connecting hoses. Various types of working Units are available for a whole range of applications. The technical data is given in sections 5 and 6.

For further information, please contact your local dealer or FIBRO GmbH
Business Unit Standard Parts

T +49 6266-73-0*, **F** +49 6266-73-237

Internet: <http://www.fibro.com>

e-mail: info@fibro.de

USER'S GUIDE FLEX CAM SYSTEM

3. DESCRIPTION OF THE COMPONENTS

3.1 Power unit (2018.20.) (Fig. 1)

The power unit (Fig. 1) consists of an accumulator (1), a driving cylinder (2) and an adapter plate (3). The accumulator is used to adjust the force of the slave and prevents excess pressure building up within the system. When the slave reaches the end of its stroke, excess oil is displaced into the accumulator (overtravel).

The cam performs the working stroke when the driving cylinder piston (4) is actuated by the press (or other machine). The power unit size is determined by the number of cams, their size and stroke length.

If space is restricted in the tool, a Power Unit with a separate accumulator is available.

➔ **When the system is totally filled with oil, the piston of the driving cylinder is at the same height as the accumulator (see figure 1).**

3.2 Cam unit

Compact cam (2018.11.) (Fig. 2)

The compact cam (Fig. 2) is suitable for work operations involving no or minimal lateral stresses. It consists of a working cylinder with piston rod (1), a working cylinder guide (2), a cylinder tube (3), the front housing (4), the rear housing (5), a bleeder nipple (6), gas springs (7), anti-rotation elements (8) and a tool holder plate (9).

The power unit starts the piston rod of the compact cam moving. The retraction motion is triggered by one or two gas springs.

The two anti-rotation elements prevent the tool holder plate from turning.

A FIBROFLEX® stripping unit is recommended for punching and cutting operations. This clamps the blank and strips it from the punch.

⚠ **Lateral forces on the Compact Cam will lead to system failure.**

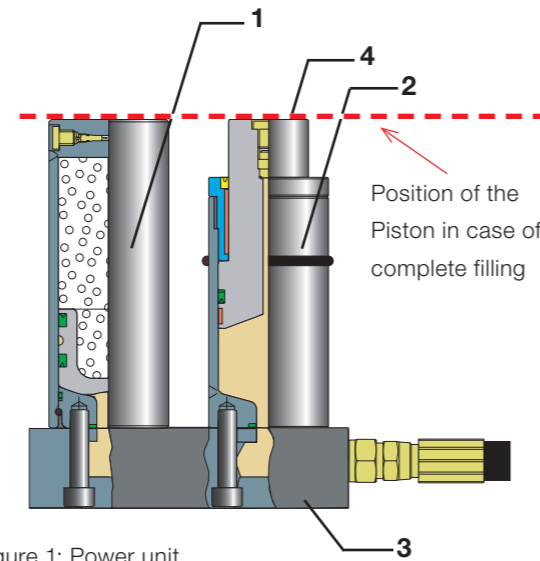

Figure 1: Power unit

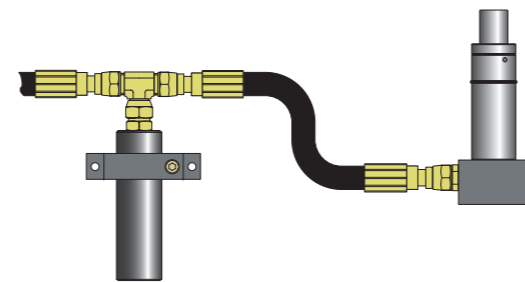

Figure 1b: Power Unit with separate accumulator

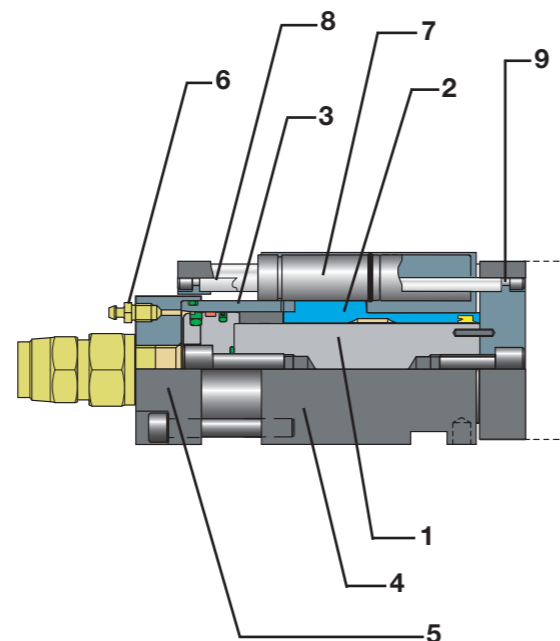

Figure 2a: Compact cam

Compact Cam with gas monitoring Connection 2018.11. xxxxx.xxx.1

In the Compact Cam with gas monitoring connection the gas springs are connected to a control fitting. This enables the pressure of the nitrogen in the gas springs to be monitored externally.

Flange Cam 2018.12.04000.049 / .1

The Flange Cam is suitable for operations with lateral forces such as flange forming.

Side forces are accommodated by an additional support for the tool holder plate (1) in the form of two rollers (2) on a support plate (4)

A Compact Cam Unit (3) is used to drive the tool holder plate.

The Power Cylinder starts the piston rod of the Flange Cam moving when pressurised and is returned by two external gas springs. The tool holder plate has tapped bores for fixing the customer tool.

Gas monitoring for the Flange Cam 2018.12.04000.049.1 (Fig. 2d) is the same Arrangement as for the Compact Cam 2018.xxxxx.xxx.1.

⚠ **A guide bolster with guide should be provided for flanging operations with asymmetrical forces**

USER'S GUIDE FLEX CAM SYSTEM

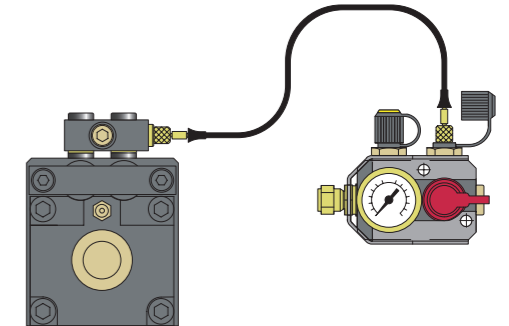

Figure 2b: Compact cam with gas monitoring

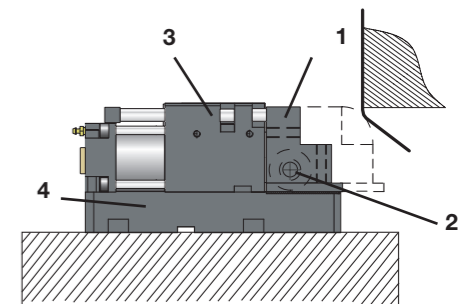

Figure 2c: Flange Cam

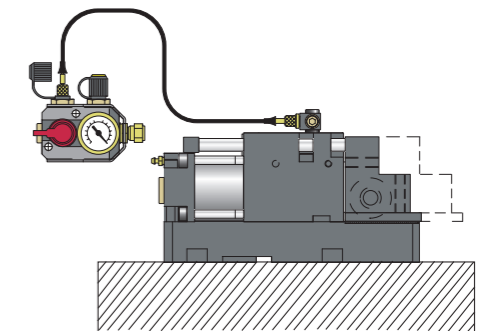

Figure 2d: Flange Cam with gas monitoring

Working cylinder (2018.30/40/50/60.) (Fig. 3)

The cylinder must be guided on the tool side. The Piston rod does not function as a guide.

➔ **It is not possible to fit a Punch directly to the piston rod!**

The working cylinder consists of a cylinder tube (1), the piston rod (2), the working cylinder guide (3), a nitrogen connection (4) and a bleeder valve (5).

The power cylinder starts the piston rod of the working cylinder movement. The cylinder retraction motion is generated by the internal nitrogen pressure. Different types of flange are used to mount the working cylinder (see also the "Hydraulic Cam System" catalogue).

➔ **The end of travel position can be set using mechanical stops inside the tool. By default, the end of travel position is limited by an internal stop at nominal stroke length.**

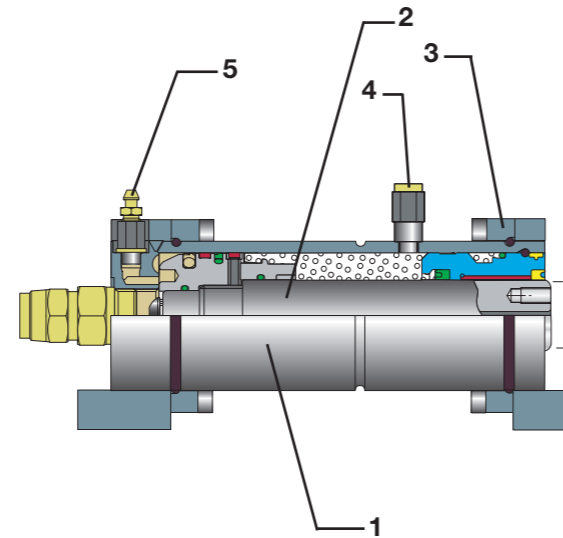

Figure 3: Working cylinder

4. DESCRIPTION OF THE FUNCTIONS

4.1 Normal operation

Figure 5 shows the power unit 2018.20. and cam unit 2018.10. The mode of operation is exactly the same for the compact cam unit 2018.11., the working cylinder 2018.30./40./50./60. and the cam unit 2018.10.

The oil pressure is 0 bar before the press (or other machine) actuates the piston of the driving cylinder. The accumulator and cam unit are filled with nitrogen (1). The press pushes against the piston of the driving cylinder (2), the Piston of the cam unit starts to move and the operation is carried out.

10 mm before bottom dead center (3), the piston of the cam unit reaches the stop and the piston in the accumulator is raised 10 mm (4).

As the press moves down again, the nitrogen pressure in the cam unit causes the working cylinder piston to retract back to the starting position.

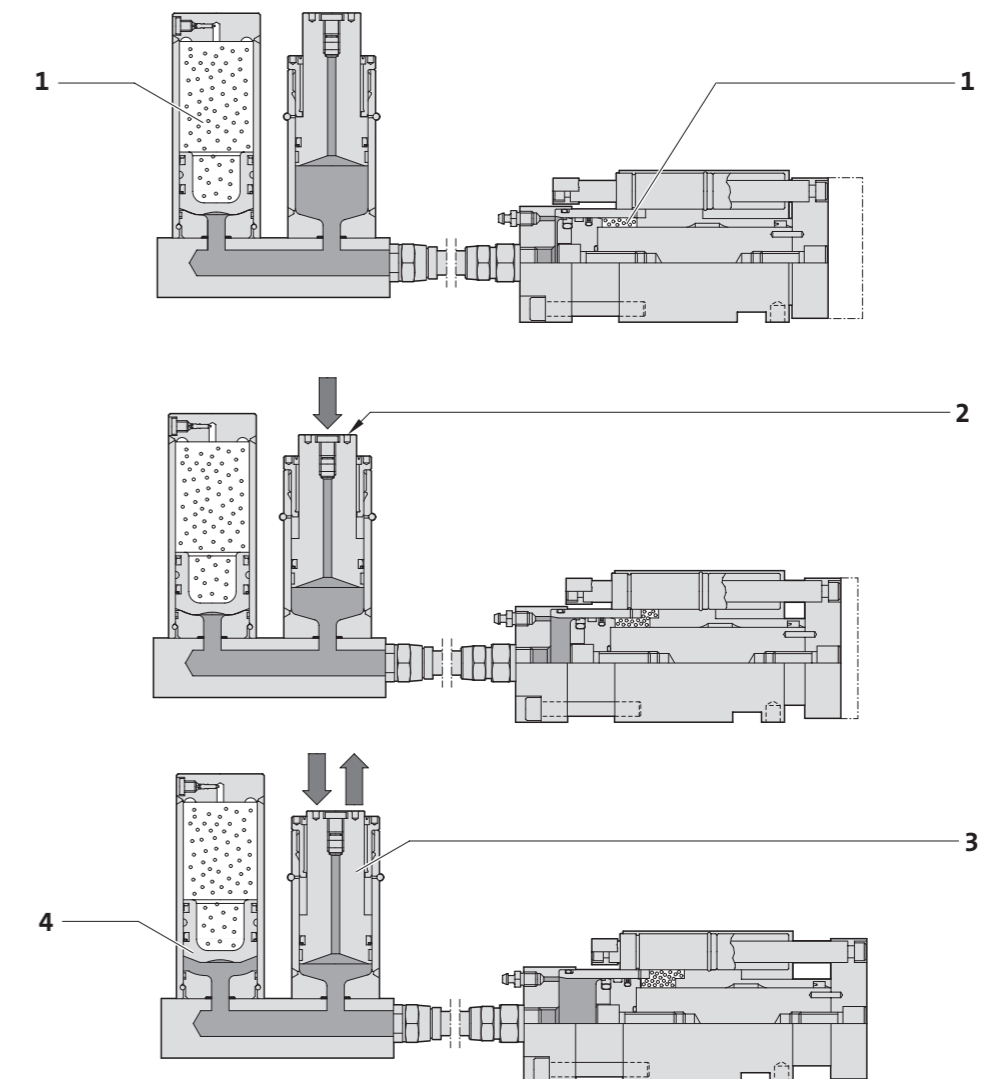

Figure 5: How the system works

USER'S GUIDE FLEX CAM SYSTEM

4.2 Safety function (Fig. 6)

If the working stroke of the cam in the press is blocked (1), the piston in the accumulator (2) is raised. The oil is displaced into the accumulator, which prevents overpressure from building up in the system (Fig. 6).

Once the fault has been eliminated, the hydraulic cam system will start to work once again more, and it will not be necessary to top up the oil in the system.

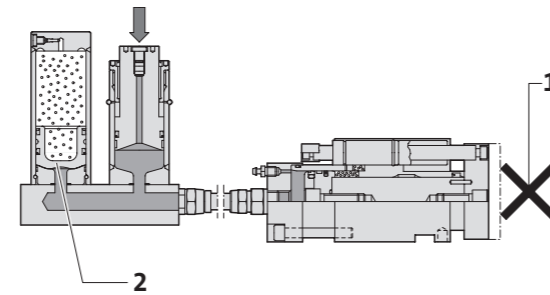

Figure 6:
Blocked system

4.3 Build-up of pressure in the system (Fig. 7)

The oil pressure is 0 bar (1) before the power unit is actuated. The oil pressure (2) corresponds to the restoring force of the cam.

The oil pressure rises to match the force generated during the operation (3).

Once the working stroke has ended, the oil pressure raises the piston in the accumulator with a force corresponding to the nitrogen pressure (4).

If the working stroke is blocked, the oil pressure describes the curve shown at (5) within the diagram.

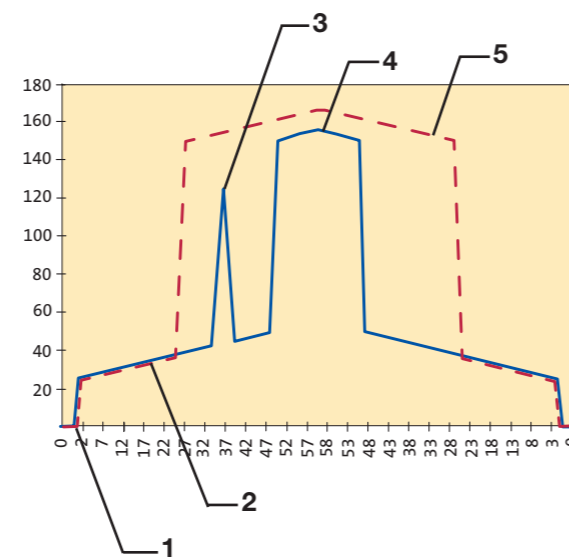

Figure 7:
Diagram of the pressure build-up

4.4 Connecting several cams to one power unit

Up to three cams may be connected to one power unit (Fig. 8).



During the stroke and before the cam have reached their end position (2), the motion of the individual cams will differ (1).

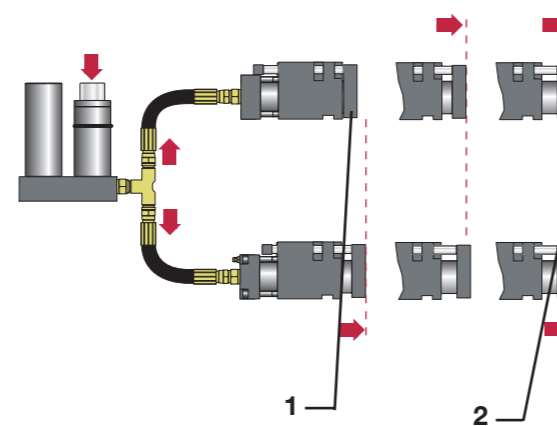

Figure 8:
Connection of two cams

4.5 Synchronous motion of two systems

For synchronous motions, we recommend the use of two separate systems (Fig. 9). One example of this is the movement of large cushions or slides within a tool.

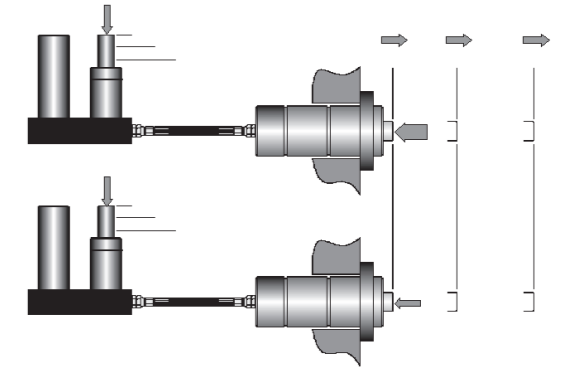

Figure 9:
Synchronized System

4.6 Transmission ratios

If a large power unit (e.g. 2018.20.04000.xxx) is connected to a smaller cam (e.g. 2018.11.01500.xxx), the stroke of the cam will increase in proportion to that of the press or power unit.

The difference between the strokes is dependent on the difference in piston diameters. The cam stroke is faster than the press stroke (Fig. 10, item 1).

$$(S_{Press} < S_{Cam})$$

The opposite can also be achieved: shorter cam stroke compared to the press stroke (Fig. 10 item 2)

$$(S_{Press} > S_{Cam})$$



The cam stroke speed must not exceed the specifications in section 6.

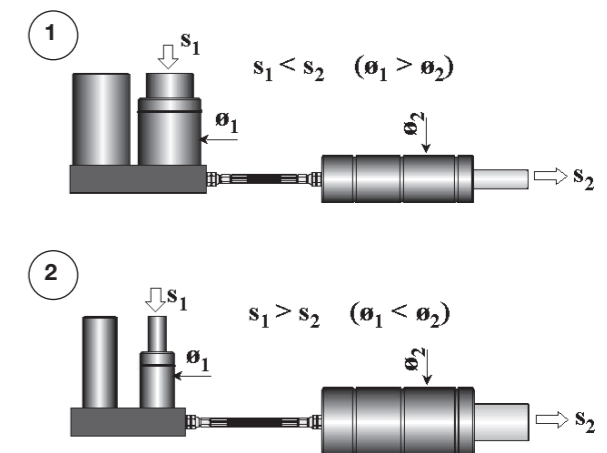

Figure 10:
Transmission ratios

5. DIMENSIONS

The dimensions are provided in the separate "Flex Cam System" catalog.

6. TECHNICAL DATA

6.1 Capacity and output

The forces listed in table 1 below are applicable for the following nitrogen gas pressures:

Accumulator	150 bar
Working cylinder	
2018.11.015-040.xxx	20 bar
Gas spring 2480.21.00200.xxx	
2018.11.09000.xxx	180 bar
Gas spring 2480.13.00500.xxx	
2018.12.04000.049	150 bar
Gas spring 2480.21. or 23.00200.xxx	180 bar

Table 1: Technical data

Description	Unit	Working cylinder					Compact cam / Flange Cam					Power unit									
		2018.30.xxxxx.xxx					2018.11.xxxxx.xxx					2018.20.xxxxx.xxx									
Force (magnitude)	kN	15	40	60	90	150	15	40	90	150	15	40	60	90	150						
Initial restoring force	kN	2	5	8	13	21	2	4	10	15	-	-	-	-	-						
Minimum gas pressure	bar	10					125					50									
Maximum gas pressure	bar	40					180					180									
Stroke length	mm	25, 50, 100, 150					24, 49, 99*					35, 60, 110, 160									
Maximum speed	m/s	0,8					0,8					0,8									
Maximum restoring force	m/s	0,8					0,8					0,8									
Maximum frequency	op/min	60					30					60					30				
Ambient temperature	°C	10-40					10-40					10-40									

* not for 2018.11.01500.

Values other than those specified in the above table may be accepted under certain circumstances or if different stroke lengths, speeds and frequencies are combined.

6.2 Other specifications

Hydraulic Oil DIN 51524 HVLP ISO VG 32

Order No.: 280.37.032.05 (5 litres) Hydraulic Oil UNIVIS N 32
 280.37.032.10 (10 litres) Hydraulic Oil UNIVIS N 32
 280.37.032.50 (50 litres) Hydraulic Oil UNIVIS N 32

Purity to ISO 4406 15/12 (with 10 µm filter)

Nitrogen gas:

Nitrogen N₂ > 99,95 vol%

Water H₂O < 40 ppm

6.3 Force of the cam as a function of the nitrogen pressure in the accumulator

If it is necessary to increase or reduce the cam force, the Nitrogen pressure may be varied in accordance with diagram 1 below.

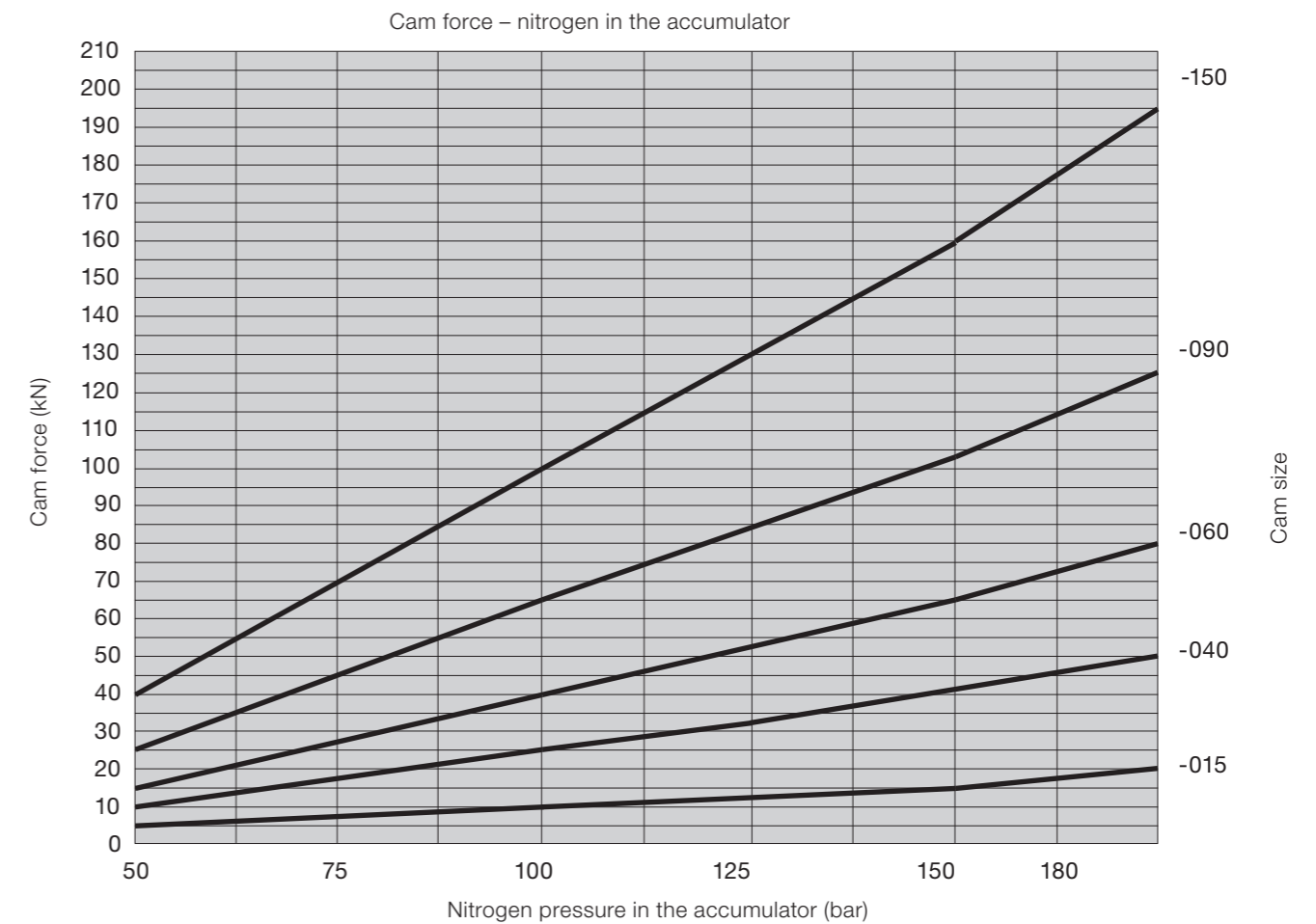

Diagrams 1:
Nitrogen pressure in the accumulator – cam force

USER'S GUIDE

FLEX CAM SYSTEM

7. SAFETY INSTRUCTIONS

7.1 Personnel

All personnel who operate and maintain the flex cam system must be entirely familiar with the way the System works. Always wash your hands after working on hydraulic systems.

7.2 Workplace

The workplace must be kept perfectly clean during assembly or maintenance work on the product.

7.3 Equipment

Always use clean tools in good working order and wear suitable protection for the skin and eyes.

7.4 Hose couplings

All hose couplings are supplied in suitable packaging. To prevent contamination by foreign bodies, do not unpack these parts until you are ready for installation.

7.5 Nitrogen products

Always act with considerable care when working with nitrogen products. Follow the special instructions for gas springs since incorrect handling can result in injury. Ensure, as well, that there is sufficient space in the tool for the accumulator.

For the safe handling of gas springs and other nitrogen products, the safety regulations must be observed. Maintenance work on the product may only be done, if nitrogen gas is no longer contained in the gas spring.

7.6 Hoses

The hoses are washed and sealed with blanking caps to prevent the ingress of dust, which could damage the system. Protect the hoses against sharp edges and external influences. The hoses move slightly during Operation due to the pulsating oil pressure.

7.7 Torque specifications for bolts

Always use a torque wrench to tighten bolts.

See table 2 below for oiled bolts conforming to DIN ISO 898 part 1, grade 12.9.,

table 3 for screw connections and

table 4 for hose fittings.

USER'S GUIDE

FLEX CAM SYSTEM

Nominal bolt dimension	Hexagon socket spanner	Torque (Nm)
M6	5	15
M8	6	40
M10	8	75
M12	10	135
M16	14	330
M20	17	640

Table 2:

Torque specifications for bolts

Size of connecting thread	Tightening torque rated (Nm)
1/2"	90
3/4"	180
1"	310
1 1/4"	450

Table 3:

Torque information for screw-in fittings

Nominal size of connection	Tightening torque rated (Nm)
DN12	50
DN20	98
DN25	140
DN32	210

Table 4:

Torque data for hose fittings

USER'S GUIDE FLEX CAM SYSTEM

8. ASSEMBLY

The next section pertains to the most important information. If you have any questions on assembly, please contact your local dealer or FIBRO GmbH.

Tel +49 6266-73-0* Fax +49 6266-73-237
Internet: <http://www.fibro.com> e-mail: info@fibro.de

8.1 Power unit (Fig. 11)

The power unit can be installed in any position in the tool, even in the top part (this applies to all units). A spacer (1) is often used and set so that the correct stroke length for the power unit is obtained.

It should be ensured that the surface of the spacer (1) that actuates the driving cylinder piston rod is parallel and flat. There must be sufficient space in the tool for the accumulator

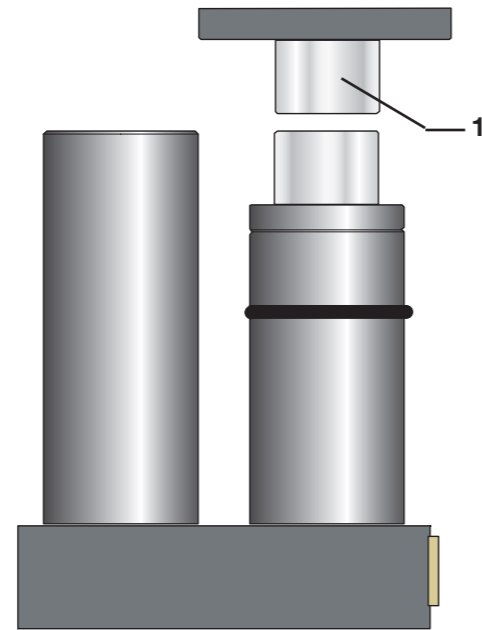

Figure 11:
Assembling the power unit with spacer

8.2 Compact cam 2018.11. (Fig. 12)

Holes for the parallel pins and bolts are drilled in the compact cam for ease of positioning. The tool holder plate (1) may be removed for assembly purposes – simply loosen the bolts (2). The opposing force of the work operation may act within the area (3) shown. However, we recommend that the force act centrally (see also section 5). There should be no torque acting on the tool holder plate (1). The gas springs (4) should be installed in the compact cam during fine adjustment of the working position (e.g. punching unit). Use the oil filling unit to move the hydraulic cam (see section 9). Use a thin blank to check the punching position and inspect for burrs, for example. This will ensure that the punch is positioned correctly.

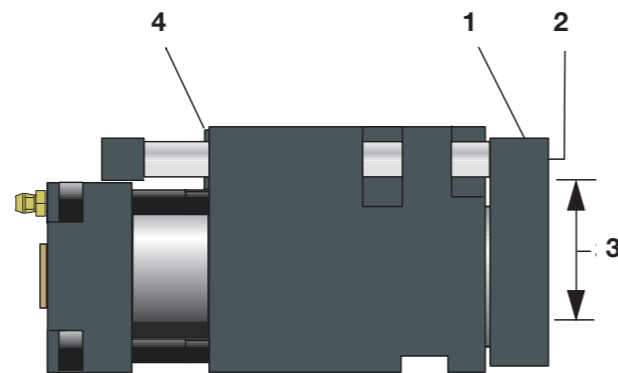

Figure 12:
Assembling the compact cam 2018.11.

8.3 Flange Cam 2018.12.04000.049

There is no restriction on the orientation of installation in the tool. Mounting kit 2018.12.01.04000.049 is used for top mounting installation (Fig. 12a).

No additional mountings are required when installation is as shown in Fig. 12b.

The customer's tool (e.g. flanging cheeks) (1) should be mounted using two or four mounting screws in the tapped bores (2) provided (Fig. 12c).

Warning: The resulting load transfer must be in the marked area.

USER'S GUIDE FLEX CAM SYSTEM

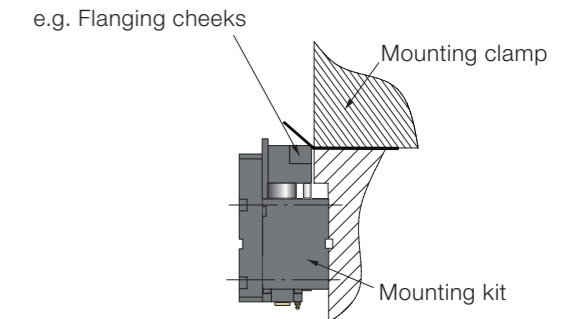

Figure 12a: Top mounting installation

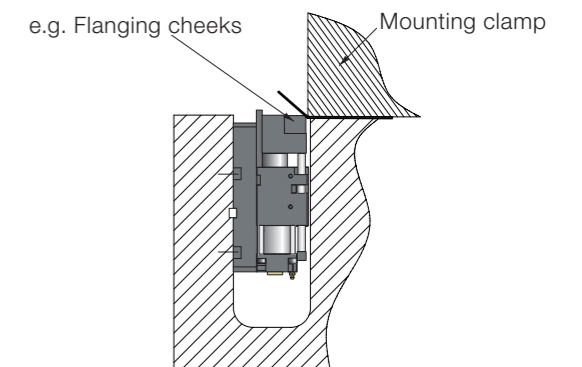

Fig. 12b: base mounting

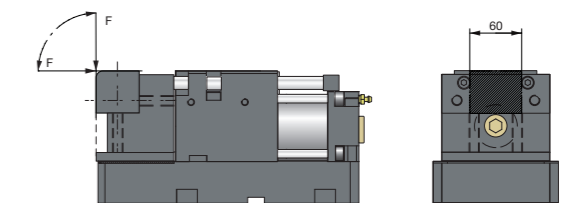

Fig. 12c: Load transfer

8.4 Working cylinder (Fig. 13)

Only use the specified mounting flanges or accessories (see the "hydraulic cam System" catalogue) for the working cylinder. The threaded holes on the top of the piston rod may be used to fit an adapter for tool for use in push & pull applications.



It is not possible for the force to be applied off-center or laterally. The cylinder force must be absorbed on the shoulder of the Fixing mount. Tensile stresses on the bolts are not permitted.

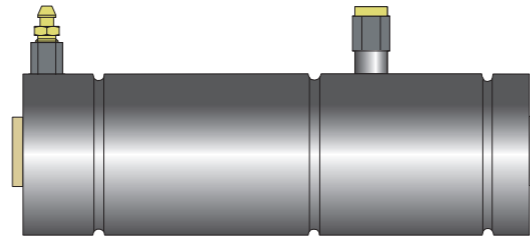

Figure 13: Working cylinder

8.5 Hydraulic hoses and couplings (Fig. 14)



See section 5 for the choice of hoses. Keep the use of couplings to a Minimum and ensure that the hose can be supplied with angled couplings.

The hoses are washed and sealed with blanking caps to prevent the ingress of dust, which could damage the system. Protect the hoses against sharp edges and external influences. The hoses move slightly during operation due to the pulsating oil pressure. Do not exceed the minimum bending radius (2). Couplings for the hydraulic cam system are supplied with an O-ring and washer. Do not forget to use them. Ensure that no moving parts come into contact with the system or hoses (see also DIN 20066).

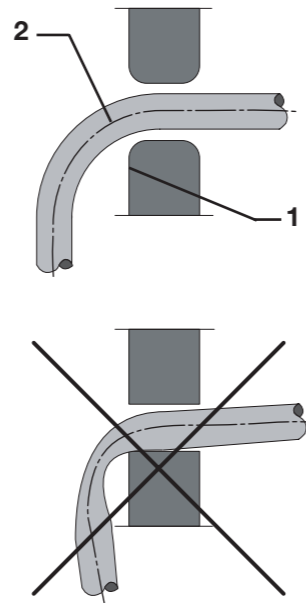

Figure 14: Fitting of hydraulic hoses

9. FILLING WITH NITROGEN GAS AND OIL

9.1 Filling the cam unit and accumulator with nitrogen gas (Fig. 16)

Equipment required:

Nitrogen cylinder, at least	180 bar
Filling and control fitting	2480.00.32.21
Fill hose	2480.00.31.02
Hexagon socket spanner	5 mm

Step 1: Connect the nitrogen cylinder

Connect the filling and control fitting to a Nitrogen cylinder (at least 180 bar pressure) by means of a filling hose.

Step 2: Fill the hydraulic cam and working cylinder (not required for the compact cam 2018.11.)

Turn the small knob (1) anticlockwise until the valve actuating pin is retracted. Connect the filling adapter (2) to the filling and control fitting. Remove the blanking plug from the cam or working cylinder, and connect the filling and control fitting by turning the large knob (3) clockwise. Carefully turn the knob (4) anticlockwise to open the nitrogen valve. Slowly fill with nitrogen gas until the manometer (5) reads 20 bar (max. 40 bar). When the desired filling pressure is reached, close the gas cylinder and open the discharge valve (6) so that any residual gas can flow out into the hose. Remove the filling and control fitting and replace the blanking plug.

To drain the cam, open the discharge valve (6) and gas valve on the hydraulic cam or working cylinder by turning the small knob (1) clockwise. Unscrew the filling and control fitting.

Step 3: Filling the Compact Cam 2018.11. xxxxx.xxx.1 and the Flange Cam 2018.12.04000.049.1

When connecting Compact Cam 2018.11.xxxxx.xxx.1 with a control fitting the gas springs are filled using the quick release coupling on the control fitting.

Compact Cam 2018.11.01500.xxx.1	180 bar
Compact Cam 2018.11.04000.xxx.1	180 bar
Compact Cam 2018.11.09000.xxx.1	150 bar

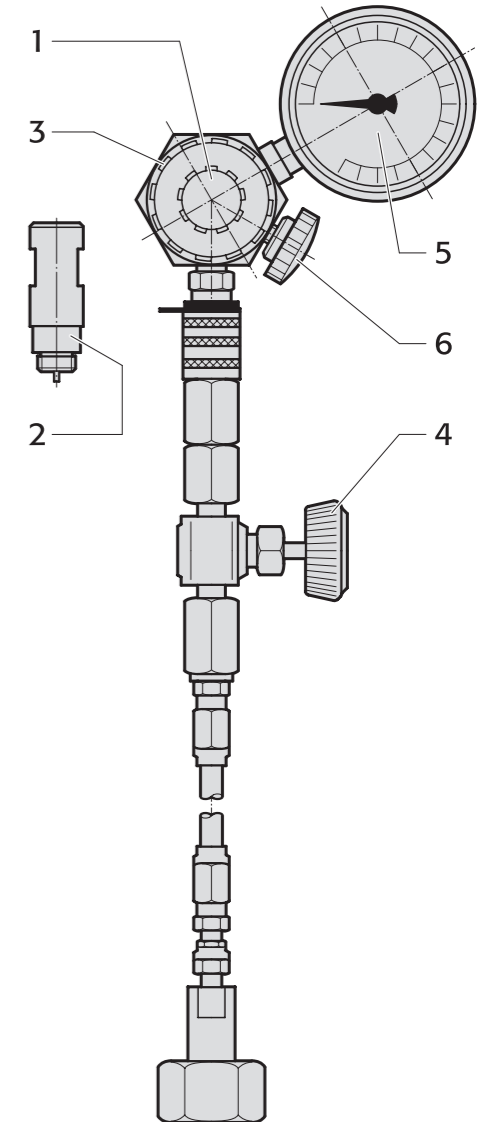

Figure 16: Filling and control fitting with filling hose



A control fitting must be connected for gas filling

Step 4: Filling the accumulator



Fill the accumulator to 25 bar as described above. After the system is filled with oil, the accumulator must be filled to 150 bar or to a different pressure as appropriate for the specific operation.

USER'S GUIDE FLEX CAM SYSTEM

9.2 FILL WITH OIL AND THEN VENT (FIG. 17A AND 17B)

Equipment	Size	Part number
Oil filling unit		2018.00.30
Oil filling fitting		2018.00.29
Face wrench	3 mm	2018.00.20.1840.03
Face wrench	5 mm	2018.00.20.1840.05
Hexagon socket spanner	6 mm	
Open-jawed spanner	11 or 14 mm	

18 l oil conforming to the specification in section 6.

Notes on compressed air

Pressure between 5 and 7 bar. A water separator, filter and automatic air line oiler must be installed in the compressed air line that supplies the compressed air motor of the oil filling unit.

Step 1: Check the nitrogen pressure before filling with oil:



Check that the cam unit or working cylinder is filled to 20 bar and the accumulator is filled to 25 bar. The area around the system must be clean and dry.

Step 2: Connect the oil filling unit:

Turn the knob (1) anticlockwise until the valve actuating pin is fully retracted. Remove the blanking plug and connect the oil filling fitting to the top of the piston (3) by turning the knob (4) clockwise. Open the valve (2) by carefully turning the knob (1) clockwise as far as the stop. Connect the transparent hose to the bleeder valve (5) and oil filling unit (6). Connect the compressed air supply to the valve (7) (G1/4" thread).

Step 3: Check freedom of movement along the cam travel:



Check that the cam moves freely and ensure that there is sufficient space available for the entire stroke.

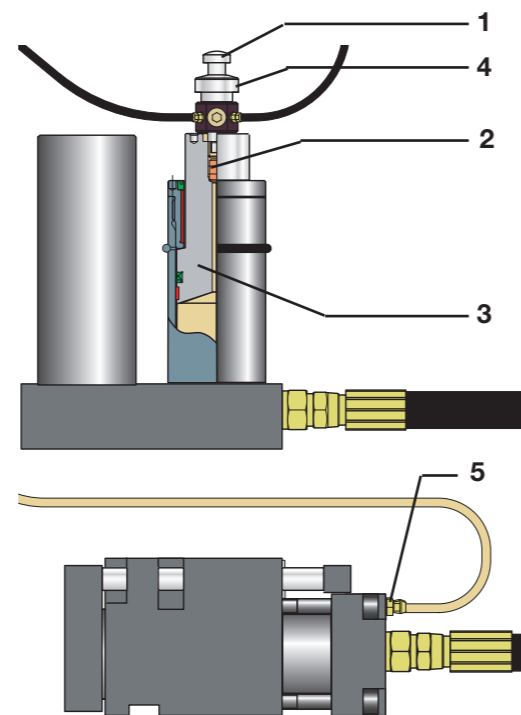
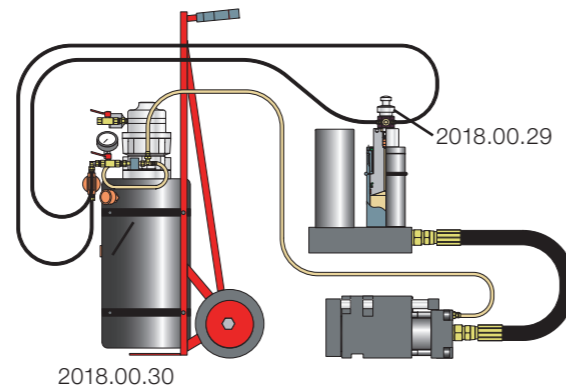

Step 4: Pump oil through the system:

Open the bleeder valve (5) and close the valve (9). Open the valve (7) and pump oil through the system until the oil is free of air bubbles.

Step 5: Vent the cam:

Fill with oil until the pressure (8) reaches 50 bar. Open the bleeder valve (5) and vent the cam. Make sure that the cam executes its full travel. Close the bleeder valve (5). Repeat the operation until the oil is free of air bubbles.

Step 6: Vent the power unit:

Fill with oil until the pressure reaches 50 bar. Open the bleeder valve (9) and vent the power unit. Close the valve (9). Repeat the operation until the oil is free of air bubbles.

Step 7: Check that the oil is free of air bubbles.



The oil pressure must be 0 bar = fully depressurised. Repeat steps 5 and 6 until the oil is totally free of air bubbles (i.e. passes through without bubbles at least 2 or 3 times).

Step 8: Test for leaks



Increase the oil pressure in the system to 50 bar and check the system for leaks at the couplings and units. Reduce the oil pressure to 0 bar. Open the bleeder valve (9) to ensure that the oil pressure is 0 bar.

Step 9: Disconnect the oil filling unit from the System:

Close the bleeder valve on the cam and clean around the valve. Remove the oil filling fitting and transparent hose. Attach the blanking plug to the top of the driving cylinder (holding the piston rod in place with the face spanner as you do so).

Step 10: Increase the nitrogen pressure in the accumulator:

The accumulator must be filled with nitrogen to 150 bar (or to the pressure required for the operation) before the system is filled with oil. The maximum pressure is 180 bar.

USER'S GUIDE FLEX CAM SYSTEM

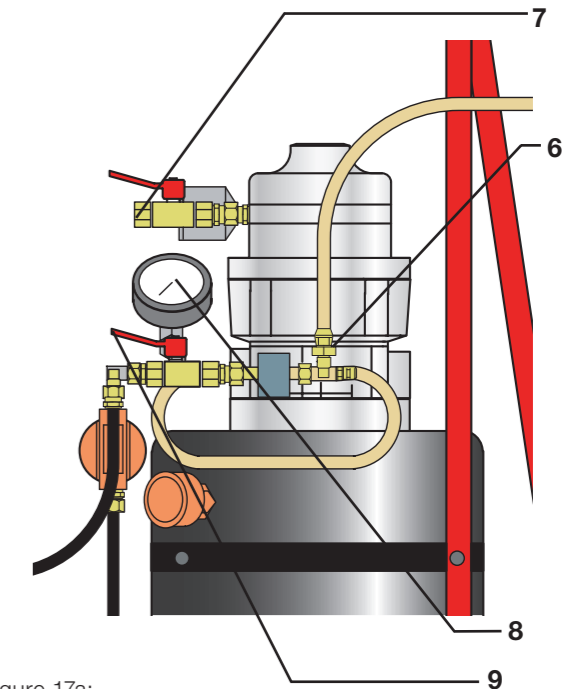

Figure 17a:
Filling with oil and venting

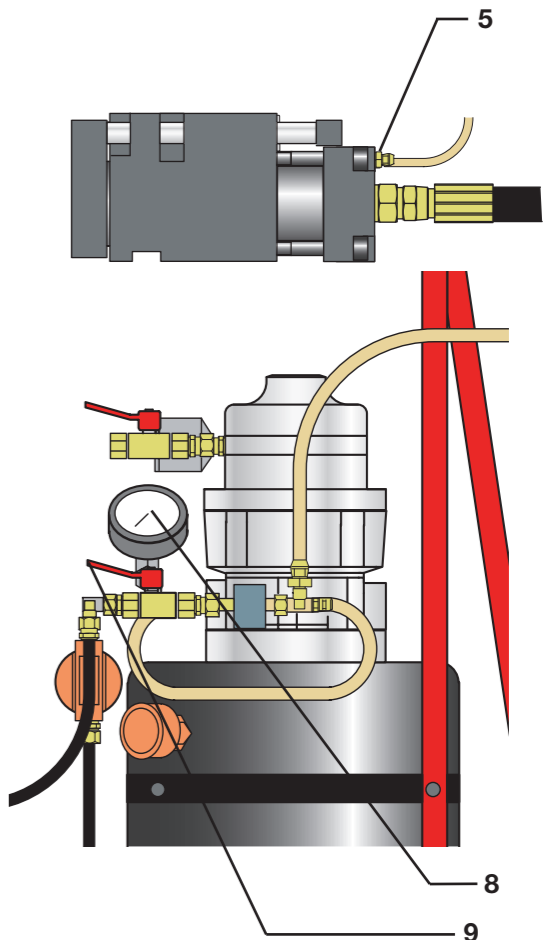

Figure 17b: Filling with oil and venting

USER'S GUIDE FLEX CAM SYSTEM

9.3 Oil Change (Fig. 18):

Carry out steps 1 to 10 as described above but, this time, connect the transparent hose (2) to a container for the used oil (1), rather than to the oil filling unit. Pump the oil until fresh oil appears in the transparent hose.

10. MAINTENANCE AND SERVICING

10.1 Power unit and working cylinder

Check the nitrogen pressure in the accumulator and working cylinder every 200,000 strokes or at least twice a year. See also section 9.

10.2 Compact cam and flange cam (fig. 19)

Check the spring force of the gas spring every 200,000 strokes or at least twice a year. To do this, remove the bolt (1) and spacer (2). Remove the gas spring using a special tool or an M3 bolt screwed into the top of the piston rod. Be careful with the O-ring that holds the gas spring centrally. Measure the force of the gas spring on a test bench (see also the maintenance and assembly instructions for gas springs 2480.21./23. and 2480.13.).

2480.21.00200.xxx: approx. 200 daN (at least 140 daN)
2480.13.00500.xxx: approx. 500 daN (at least 350 daN)

The gas spring should be replaced if the spring force is below the minimum (value).

2018.11.01500.xxx	xxx = Stroke length
1x Gas spring:	2480.21.00200.xxx
2018.11./12.04000.xxx	xxx = Stroke length
2x Gas spring:	2480.21.00200.xxx
2018.11.09000.xxx	xxx = Stroke length
2x Gas spring:	2480.13.00500.xxx

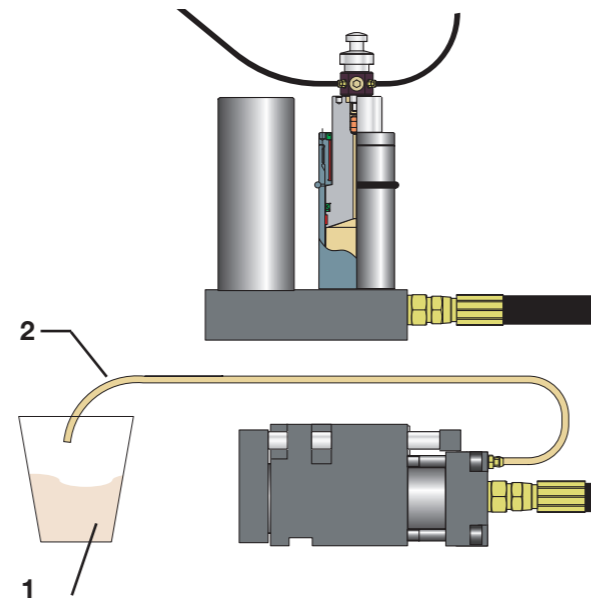

Figure 18: Oil change

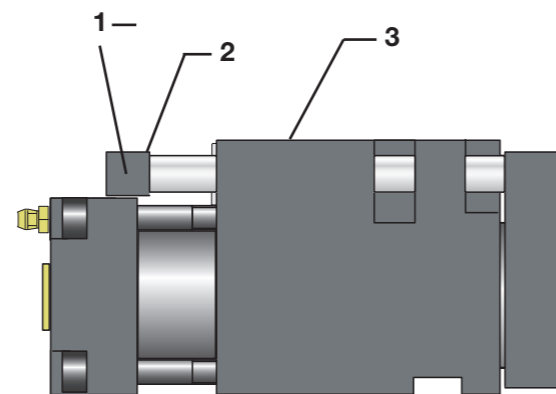

Figure 19:
Compact cam

With compact cam 2018.11.xxxxx.xxx.1 and flange cam 2018.12.04000.xxx.1 check nitrogen pressure in the gas springs permanently or every 200,000 strokes or twice a year.

2018.11.01500.xxx.1	180 bar (min. 125 bar)
2018.11.04000.xxx.1	180 bar (min. 125 bar)
2018.11.09000.xxx.1	150 bar (min. 105 bar)

If nitrogen pressure is below the figures stated above check composite connection and replace gas springs if necessary.

2018.11.01500.xxx.1	xxx = Stroke length
1 x Gas spring:	2480.23.00000.xxx
2018.11./12.04000.xxx.1	xxx = Stroke length
2 x Gas spring:	2480.23.00000.xxx
2018.11.09000.xxx.1	xxx = Stroke length
2 x Gas spring:	2480.13.00500.xxx



With gas spring 2480.13.00500.xxx remove valve before interconnecting. No oil must leak.

10.4 Oil

The oil should be changed after the initial running-in phase of 100 to 1000 strokes. Thereafter, the oil should be changed every 500,000 strokes or at least every two years. When the oil is changed, the old oil must be pumped out of the system (see also section 6.2 and 9.3).

10.5 Oil filling unit (Fig. 21)

Replace the filter (1) and transparent hose (2) every 200 operating hours or at least every two years. Remove the entire filter by detaching the connector and hose. Clamp the filter in a vice and remove the bottom by turning it anticlockwise. Remove the old filter and insert a new filter together with the stop washer.

Oil filling unit complete	Order No.:	2018.00.30
Filter	Order No.:	2018.00.30.01
Transparent hose	Order No.:	2018.00.30.02

USER'S GUIDE FLEX CAM SYSTEM

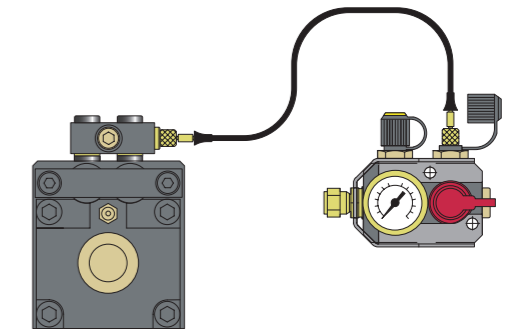

Figure 20:
Compact cam with gas monitoring

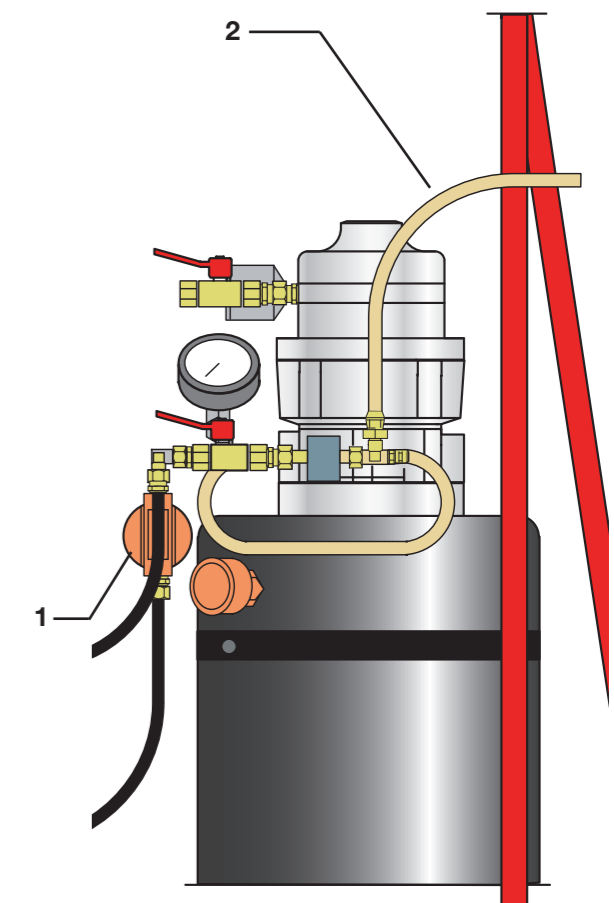

Figure 21:
Oil filling unit

10.6 Service

The flex cam system contains highly pressurised nitrogen gas.



It must only be maintained and repaired by trained, authorised personnel.

If you have any questions about the system, please contact your local dealer or FIBRO GmbH.

10.7 Trouble shooting Guide

Type of fault	Possible cause	Action
The cam does not execute its full stroke	Low gas pressure in the accumulator	Increase the gas pressure (see section 9) (Attention: Maximum pressure 180 bar)
	The driving cylinder does not execute its full stroke	Adjust the stroke
	Oil leaking into the driving cylinder:	
	A. The cover has worked loose	A. Fill the system (see section 9) Replace the blanking plug, if necessary
	B. Damage to the seal and/or internal Damage to driving cylinder	B. Replace the entire power unit
Working cylinder does not retract	Oil leaking into the working cylinder / hydraulic cam	Replace the entire working cylinder / hydraulic cam
	The hose or connecting lines have worked themselves loose	Replace the defective parts and refill the system (see section 9)
	Low gas pressure in the working cylinder	Increase the gas pressure (see section 9)
	Attention: Check the gas pressure once the working cylinder has retracted (if the gas pressure is OK: gas will leak from the accumulator into the oil)	Attention: Maximum pressure 40 bar. If the gas quickly emerges once again, replace the working cylinder / hydraulic cam
	Gas leaking from the accumulator into the oil	Drain off the oil (gas bubbles in the oil). Replace the power unit as soon as possible
	Damage to working cylinder	Replace the working cylinder / hydraulic cam
	System incorrectly filled with oil and gas (oil in the system is not depressurised)	Refill the system (see section 9)
	Bolts have broken. If this is the case, the intermediate plate and working cylinder guide can be moved manually back and forth	Replace the bolts. If you cannot remove the old, broken bolts, replace the entire working cylinder / hydraulic cam

FIBRO GMBH

Business Unit Standard Parts
August-Läpple-Weg
74855 Hassmersheim
GERMANY
T +49 6266 73-0
info@fibro.de
www.fibro.com

THE LÄPPLE GROUP

LÄPPLE AUTOMOTIVE
FIBRO
FIBRO LÄPPLE TECHNOLOGY
LÄPPLE AUS- UND WEITERBILDUNG